

LIGHT STANDARD DETAILS

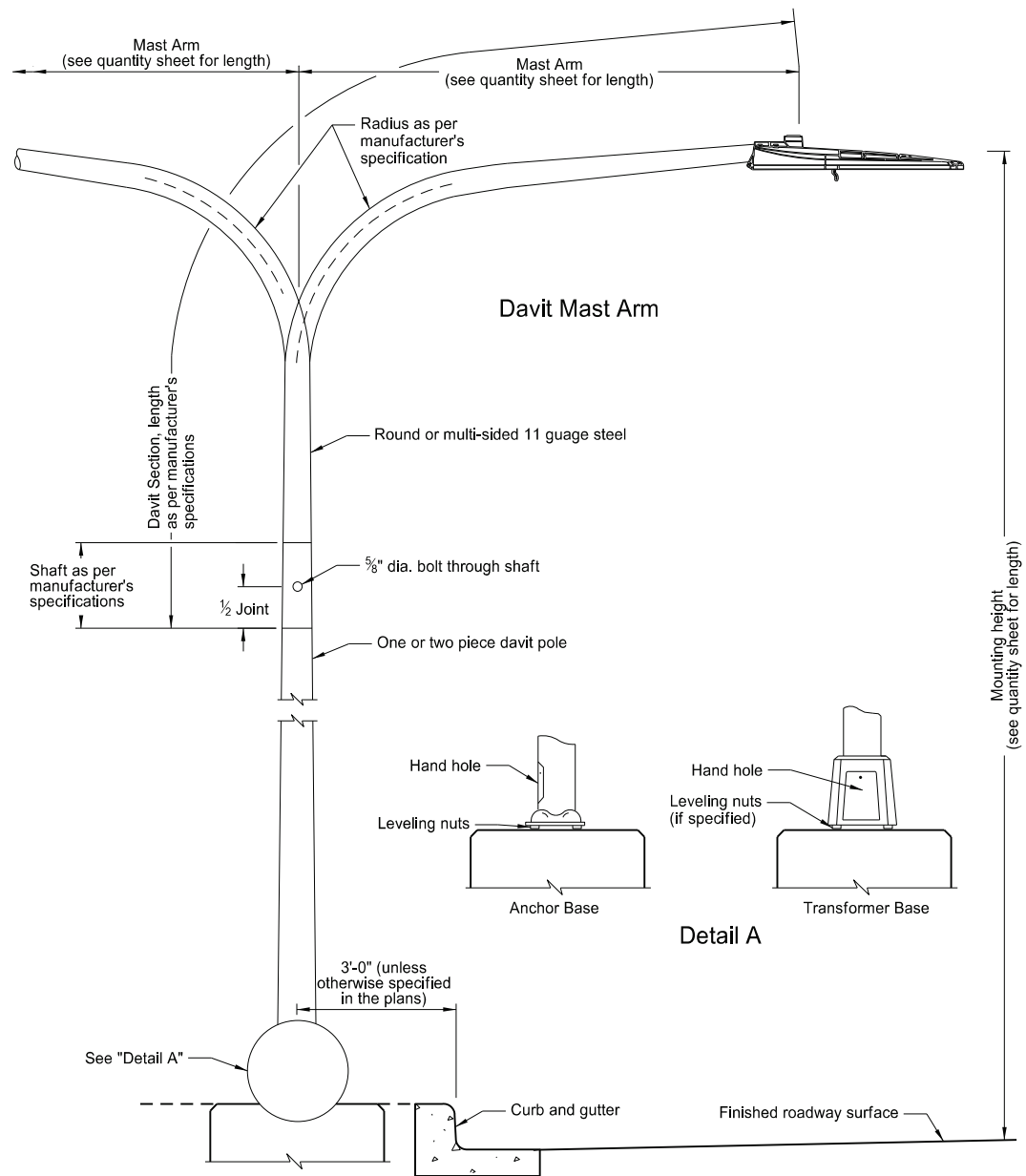

Light Standard Details

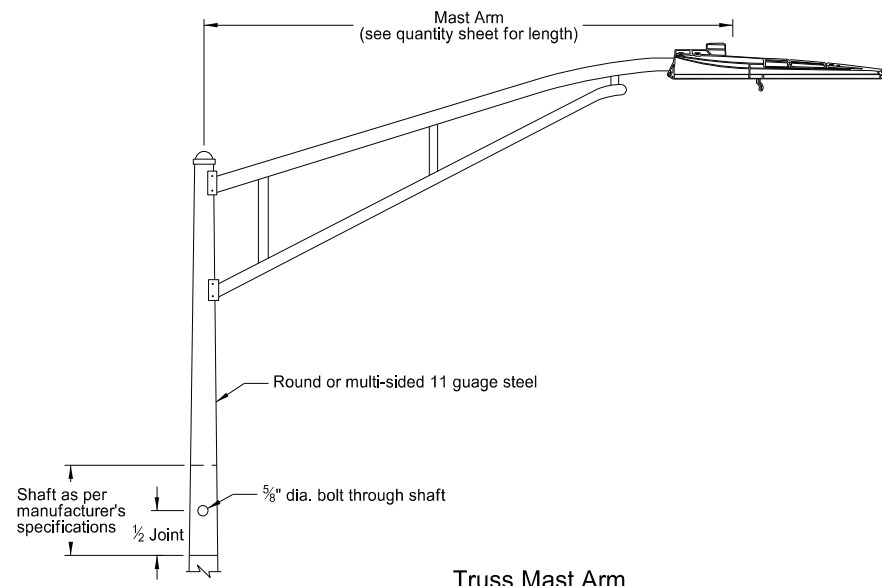

Truss Mast Arm

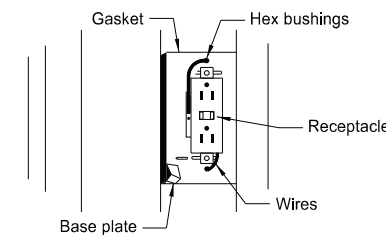

Optional: Festoon receptacle mounted on multi-sided pole.

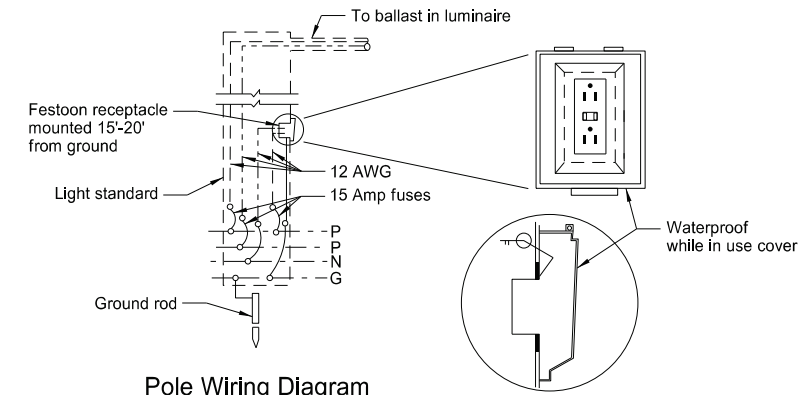

Pole Wiring Diagram

Receptacle Mounting Detail (B)

(B) Mount receptacle on side of pole that faces the street. Install Festoon Receptacle only when specified in the plans.

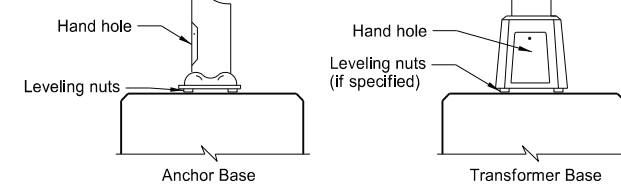

Detail A

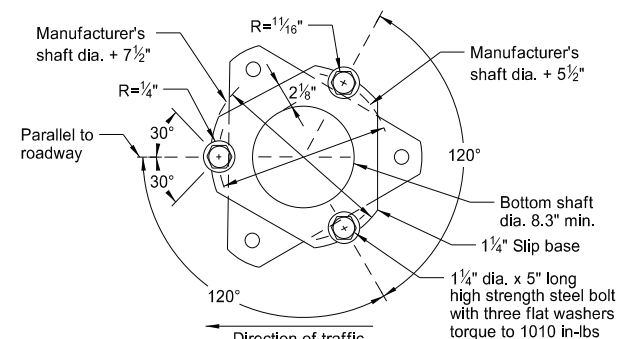

Top View

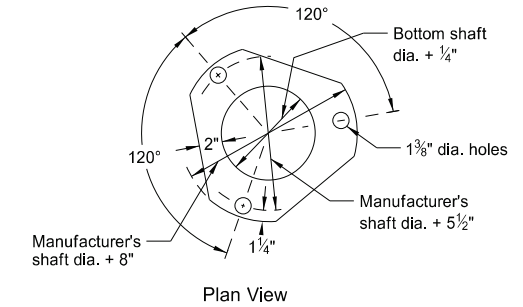

Keeper Plate Detail (A)

(A) ASTM A446 Grade "A" 28 gauge keeper plate on top of middle flat washer. Galvanize Keeper plate after fabrication.

Notes:

Light Standard Locations: The minimum offset distance from the curb face is 3 feet. Offset light standards at least 3 feet in urban areas and where speeds are less than 30 mph. Where speeds are 30 mph or more, place light standards at least 16 feet from the driving lane.

Steel Standards: Touch up marred or scratched areas after erection.

Luminaire: Use internal ballast-constant wattage 120x240 voltage. See layout sheets for type of luminaire, wattage, I.E.S. distribution, and operating system.

Fusing: Fusing in base, see specifications.

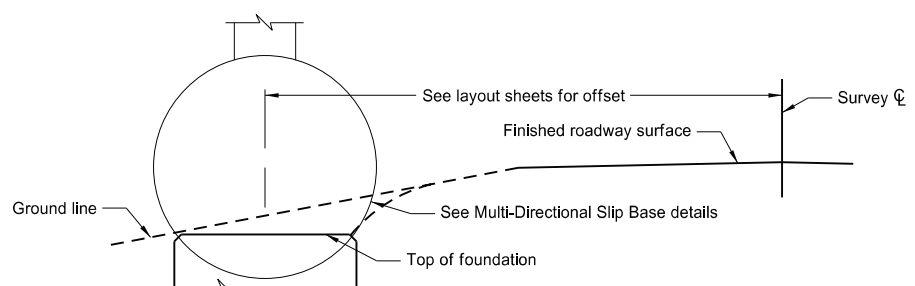

Concrete Foundation Location

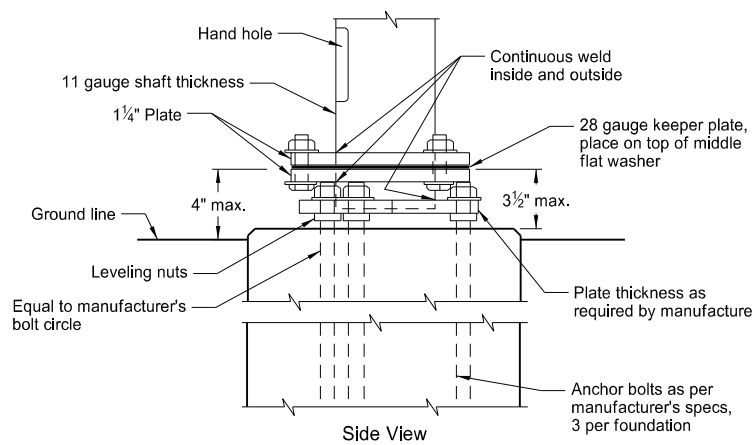

Steel Base Detail

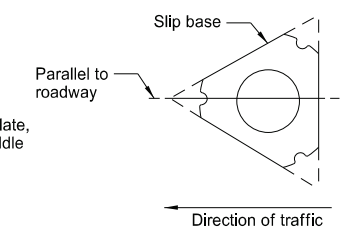

Slip Base Placement Detail

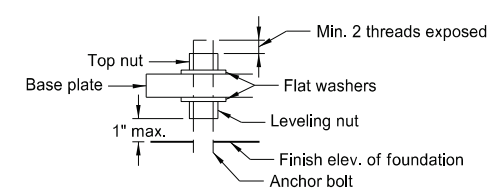

Anchor Bolt Detail

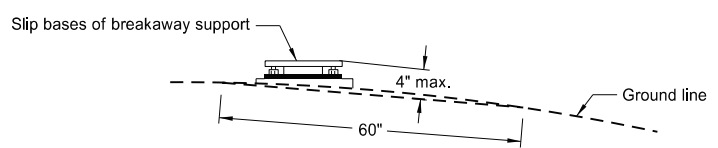

Breakaway Support Stub Clearance Diagram

Multi-Directional Slip Base

NORTH DAKOTA DEPARTMENT OF TRANSPORTATION	
10-8-13	
REVISIONS	
DATE	CHANGE
10-17-17	Updated to active voice.
08-28-19	New Design Engineer PE Stamp.
11-01-24	Revised luminaire details/notes.

