

TRUCK INSPECTION ROADSIDE SITE
PULLEY WINCH FOR 6' X 3.5' SIGN

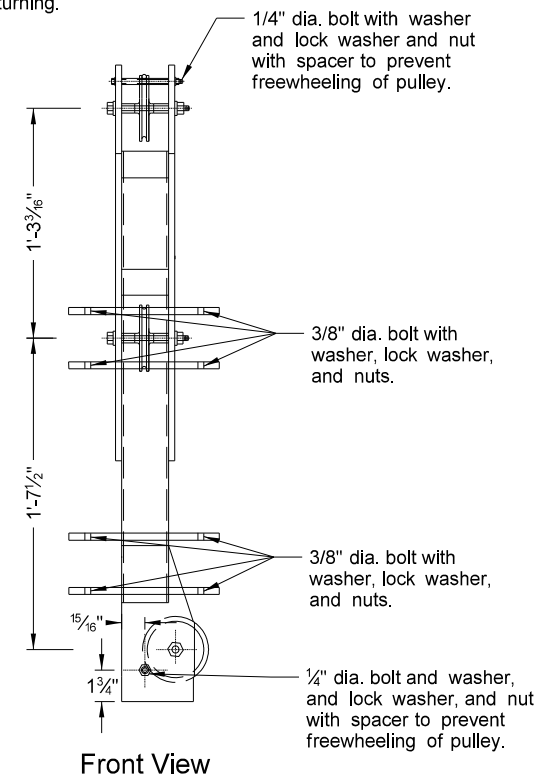

Detail B

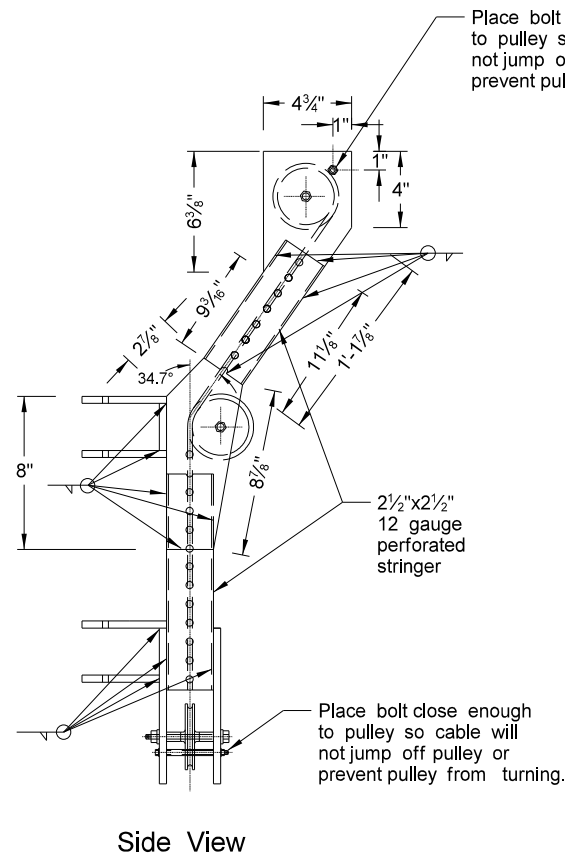
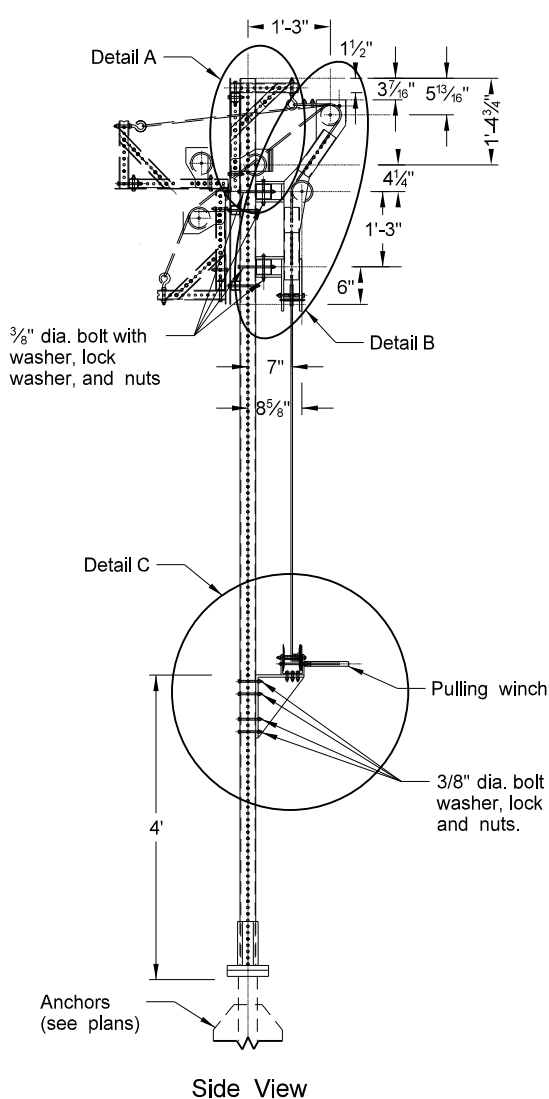
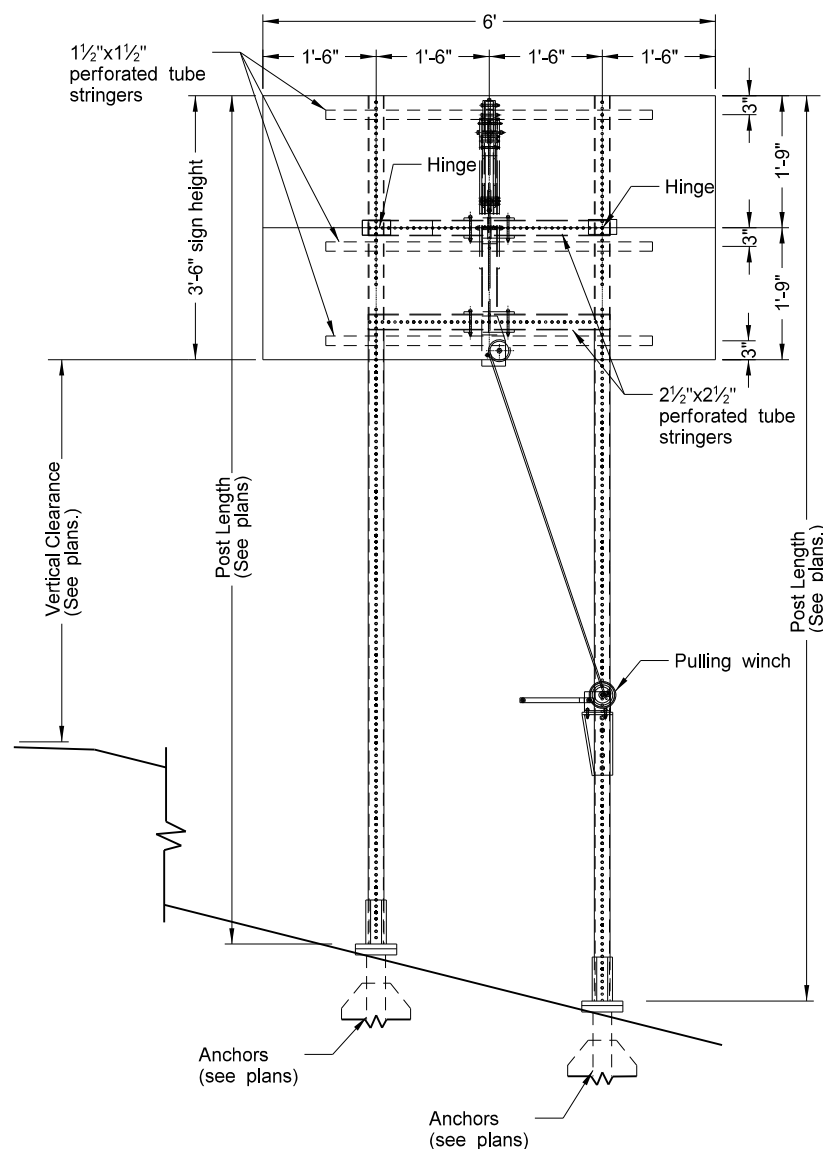
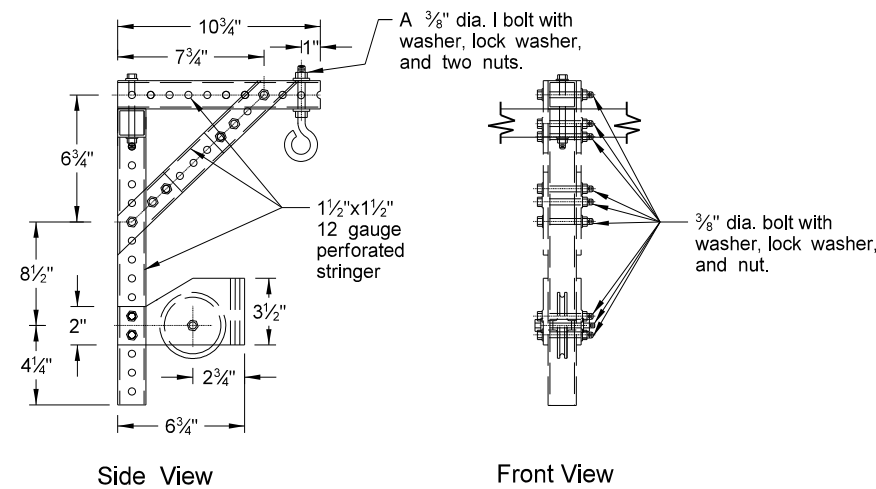
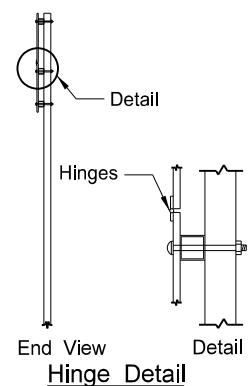

Detail A

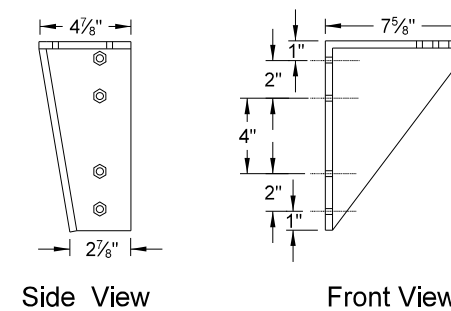

Detail C

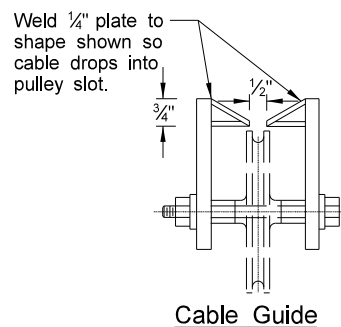

Notes:

Use minimum 0.100 inch thickness sign backing material.

Punch holes round for 3/8" bolt.

Pulling Winch: Build winch for lifting and pulling operations with self locking mechanism. Use winch and cable attachment in compliance with SAE Standard J1853 and mount using three 3/8" diameter bolts, washers and lock washers.

Use laminated, high carbon steel gears. Copper braze drive gears and arc weld gears. Rigid weld reel for added strength. Assure reel is free wheeling when ratchet is disengaged. Match gear ratio for easy cranking. Use zinc plated finish. Use heavy duty steel with molded grips for handle and embossed reinforced steel base. Provide permanently lubricated bearings for drive shafts. Include cable clamp. Provide large hub for pulling winch for use with cable operation.

Use 3/8" thick steel plate conforming to AASHTO M270 Grade 36 and galvanized in conformance with ASTM A153 for pulling winch and pulley attachment hardware. Provide pulleys of approximately 3" diameter plus a 3/8" diameter cable ride. Use spacers between the hub and the attachment brackets so pulleys ride in the center of brackets without moving back and forth. Fabricate bolts, nuts, and washers of steel meeting ASTM A307 and galvanized in conformance with ASTM A153.

Use double galvanized 7 strand steel wire cable not less than 3/8" diameter meeting ASTM A475.

Use 4" wide x 2" deep x 1/8" thick stainless steel hinges with 4-3/16" Dia [#10-24] x 5/8" long slotted countersunk flat head stainless steel stove bolts/machine screws with stainless steel locking nuts to attach to extruded panels. Place centerline of hinge pin with offset letters so sign will hang down vertically.

NORTH DAKOTA DEPARTMENT OF TRANSPORTATION	
09-27-13	
REVISIONS	
DATE	CHANGE
8-30-18	Updated notes to active voice.
9-05-19	New Design Engineer PE Stamp.

This document was originally issued and sealed by
Kirk J Hoff,
Registration Number
PE- 4683,
on 9/05/19 and the original document is stored at the North Dakota Department of Transportation