

SIGN PUNCHING, STRINGER AND SUPPORT LOCATION DETAILS - ROUTE MARKER SIGNS

D-754-55

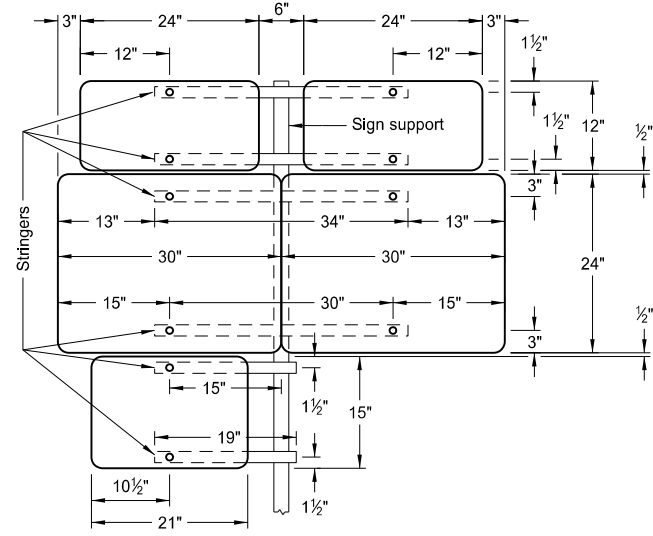

1 Post

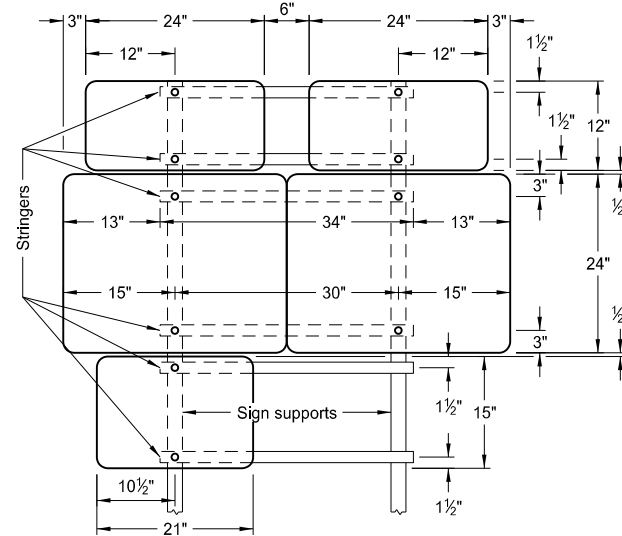

2 Posts

ASSEMBLY 386

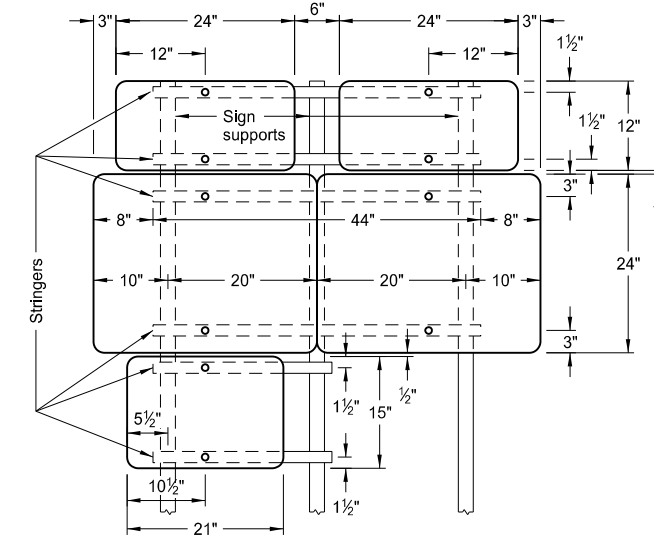

3 Posts

Notes:

1. Use 0.100 inch minimum thickness sign backing material.
2. Use 1 1/2"x1 1/2" perforated square tube stringers.
3. Punch holes round for 3/8" bolt.

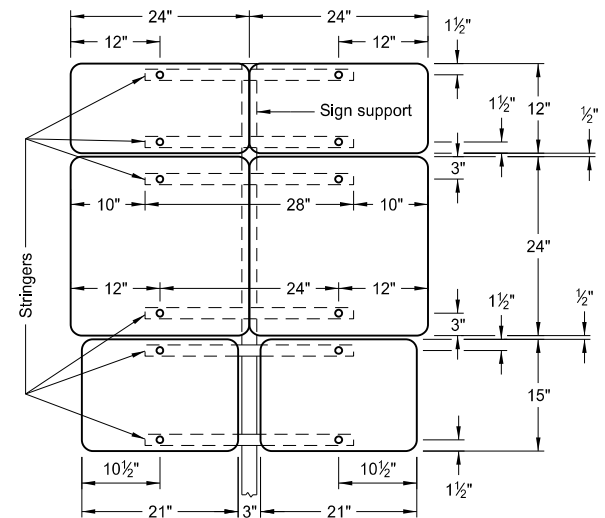

1 Post

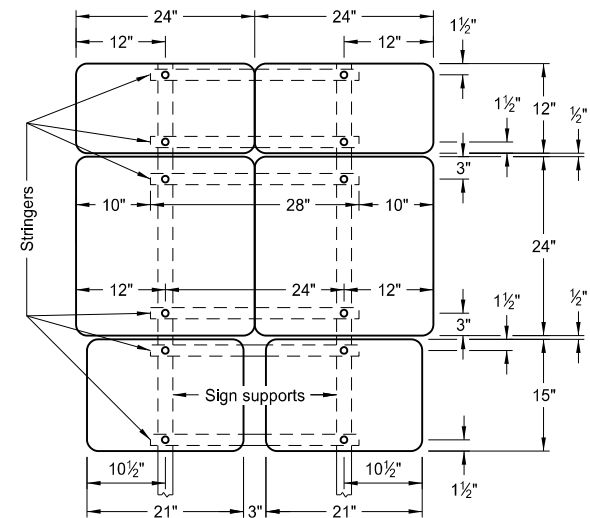

2 Posts

ASSEMBLY 387

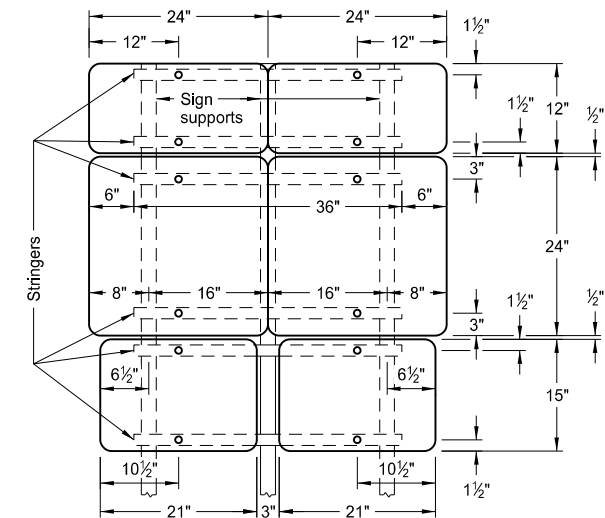

3 Posts

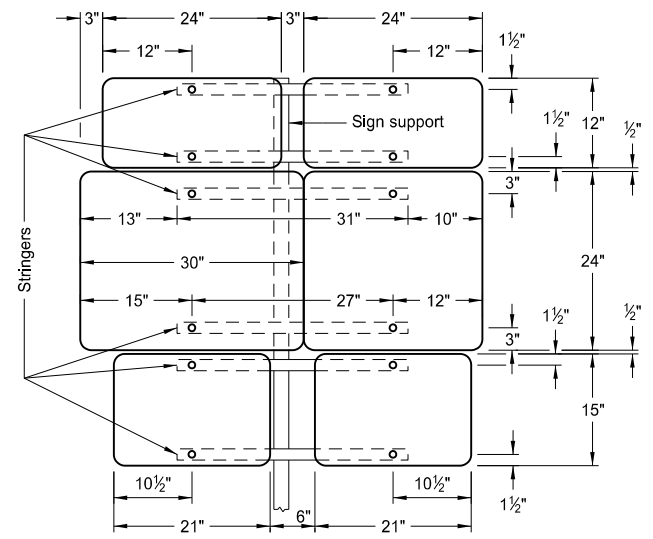

1 Post

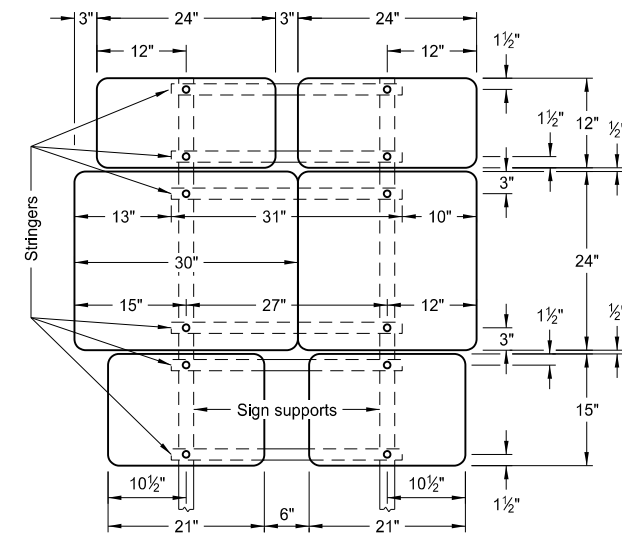

2 Posts

ASSEMBLY 388

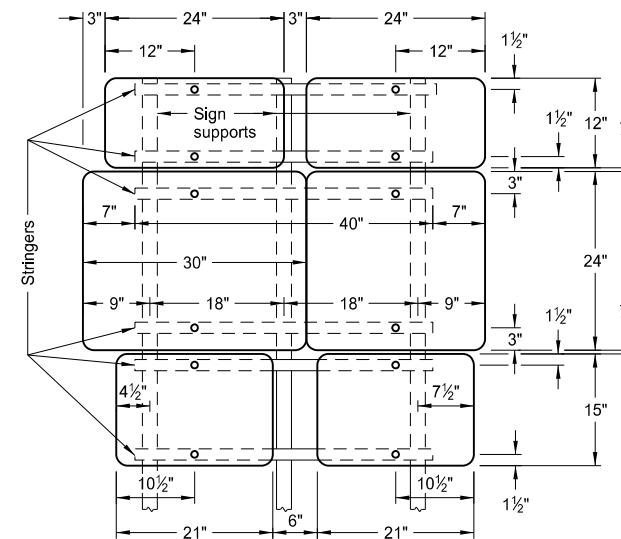

3 Posts

NORTH DAKOTA DEPARTMENT OF TRANSPORTATION	
8-22-12	
REVISIONS	
DATE	CHANGE
8-30-18 9-04-19	Updated notes to active voice. New Design Engineer PE Stamp.

This document was originally issued and sealed by Kirk J Hoff, Registration Number PE- 4683, on 9/04/19 and the original document is stored at the North Dakota Department of Transportation