

SIGN PUNCHING, STRINGER AND SUPPORT LOCATION DETAILS - ROUTE MARKER SIGNS

D-754-54

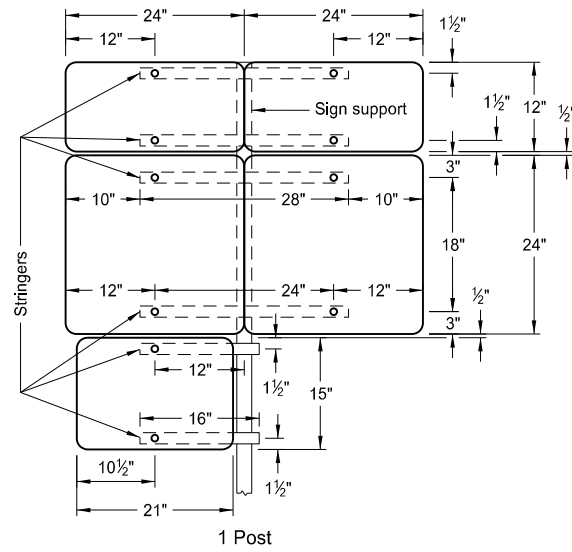

1 Post

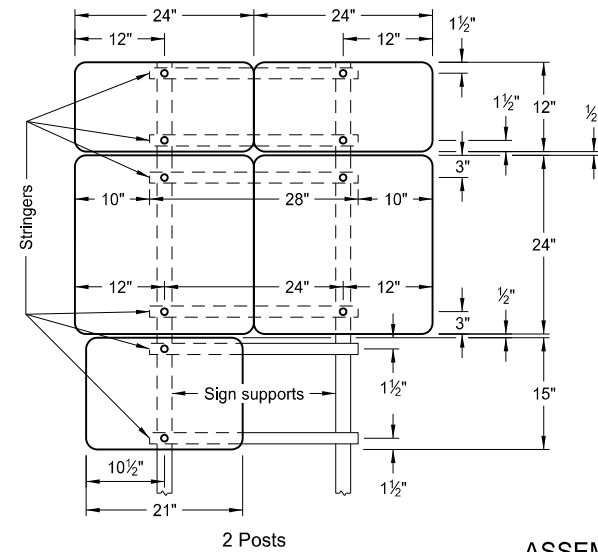

2 Posts

ASSEMBLY 383

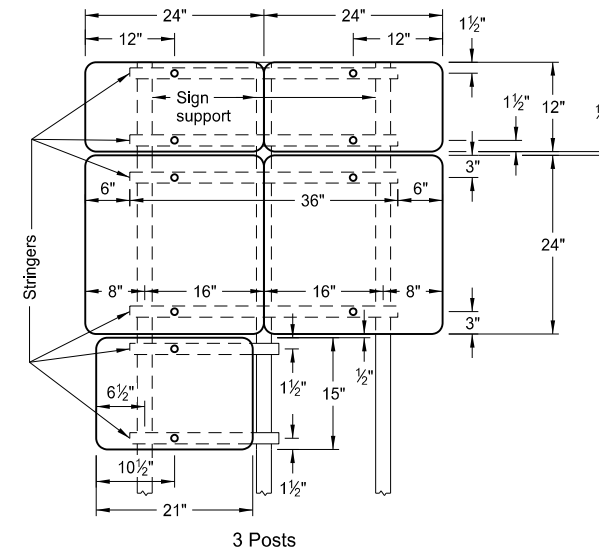

3 Posts

Notes:

1. Use 0.100 inch minimum thickness sign backing material.
2. Use 1 1/2"x1 1/2" perforated square tube stringers.
3. Punch holes round for 3/8" bolt.

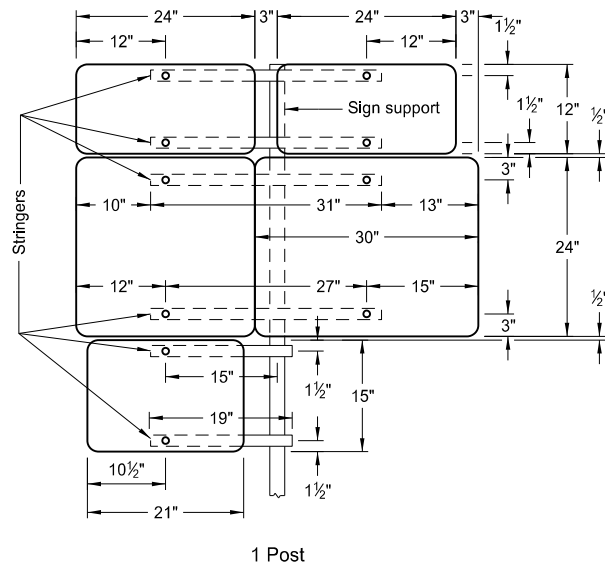

1 Post

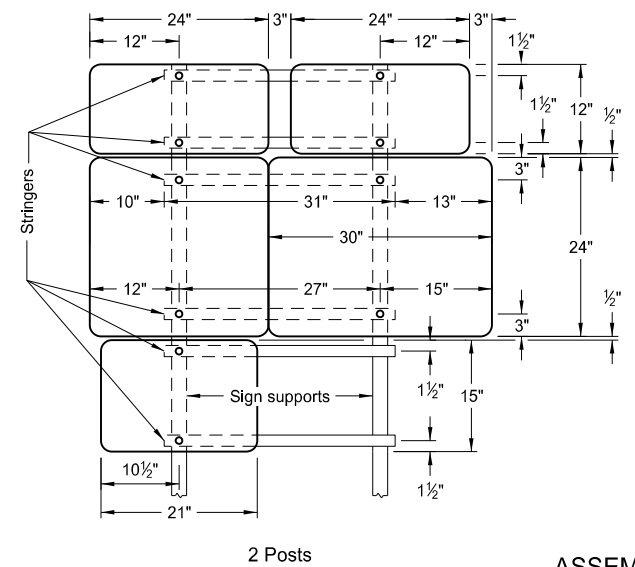

2 Posts

ASSEMBLY 384

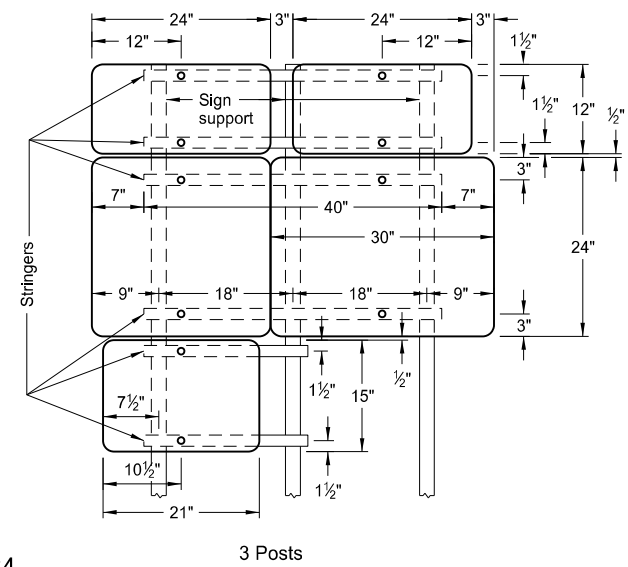

3 Posts

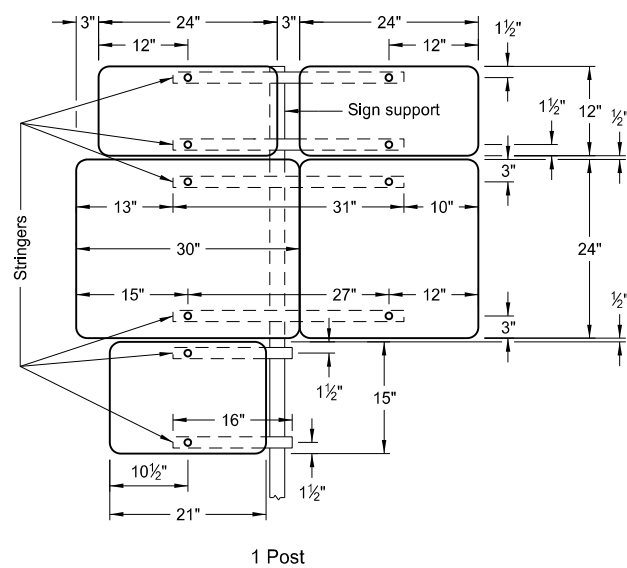

1 Post

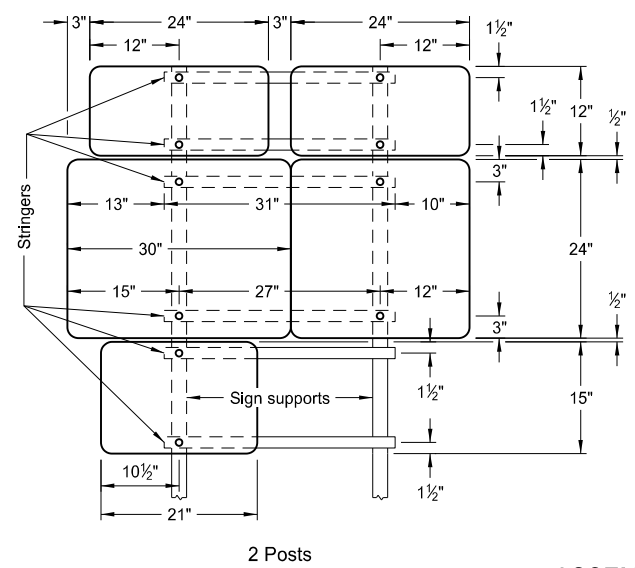

2 Posts

ASSEMBLY 385

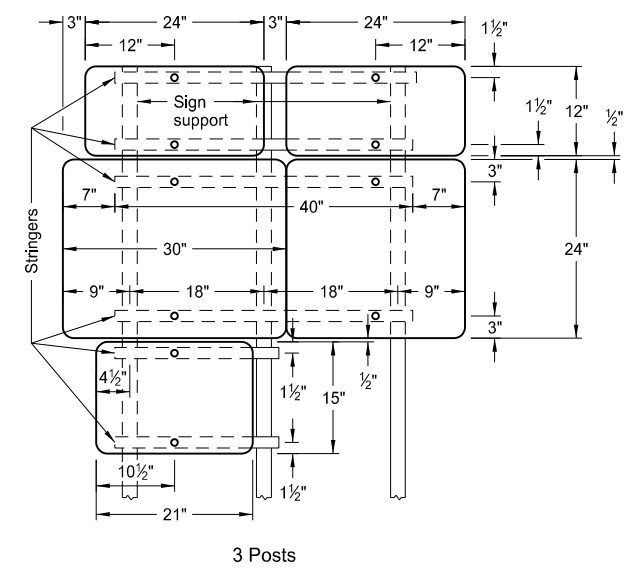

3 Posts

NORTH DAKOTA DEPARTMENT OF TRANSPORTATION	
8-22-12	
REVISIONS	
DATE	CHANGE
8-30-18	Updated notes to active voice.
9-04-19	New Design Engineer PE Stamp.

This document was originally issued and sealed by
 Kirk J Hoff,
 Registration Number
 PE- 4683,
 on 9/04/19 and the original document is stored at the
 North Dakota Department
 of Transportation