

SIGN PUNCHING, STRINGER AND SUPPORT LOCATION DETAILS - ROUTE MARKER SIGNS

D-754-51

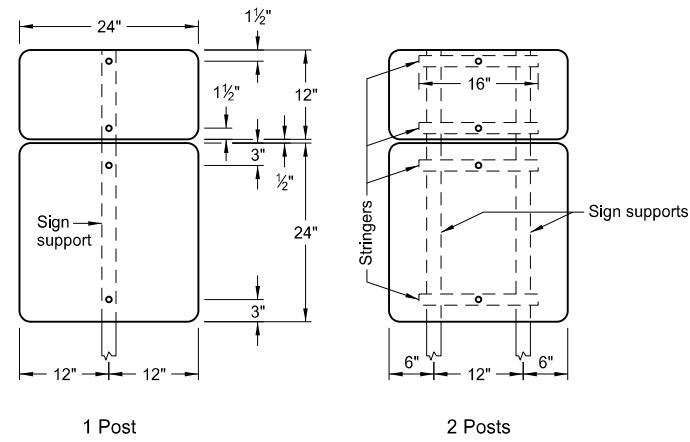

ASSEMBLY NO. 371

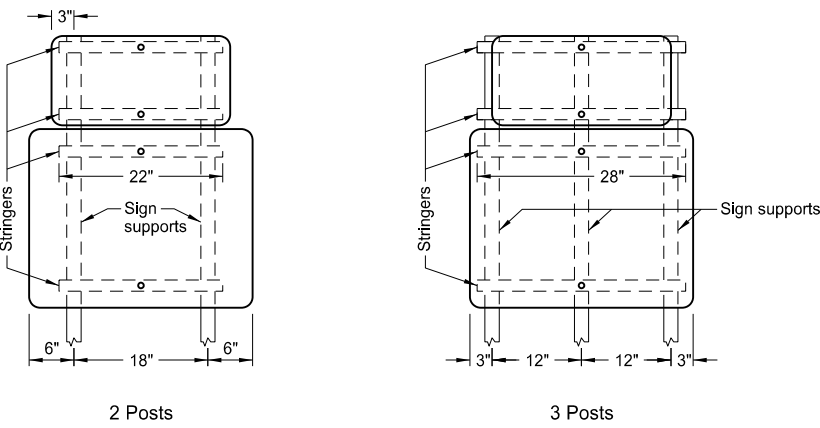
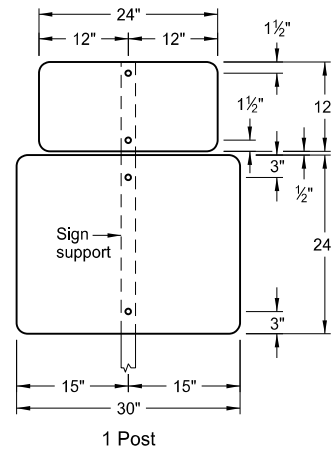

ASSEMBLY NO. 372

Notes:

1. Use 0.100 inch minimum thickness sign backing material.
2. Use 1 1/2"x1 1/2" perforated square tube stringers.
3. Punch holes round for 3/8" bolt.

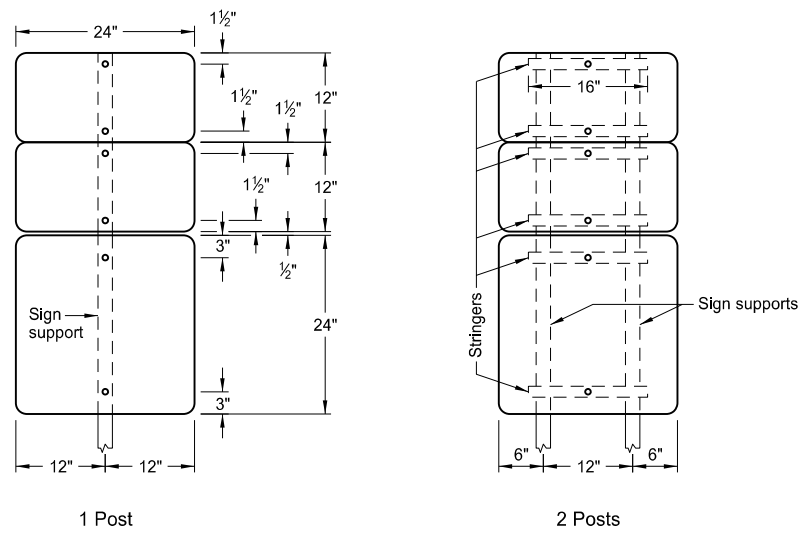

ASSEMBLY NO. 373

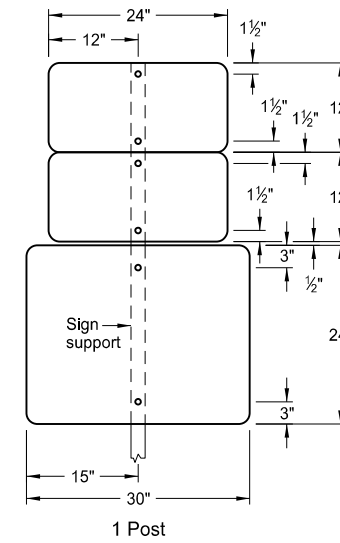
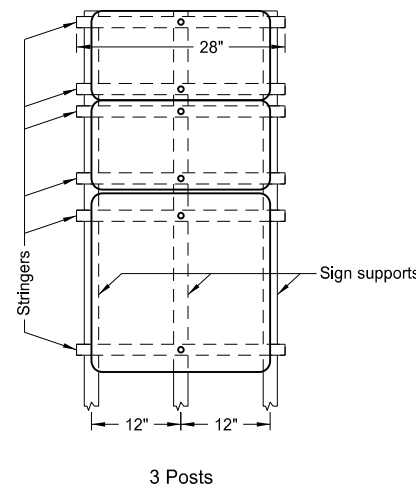

ASSEMBLY NO. 374

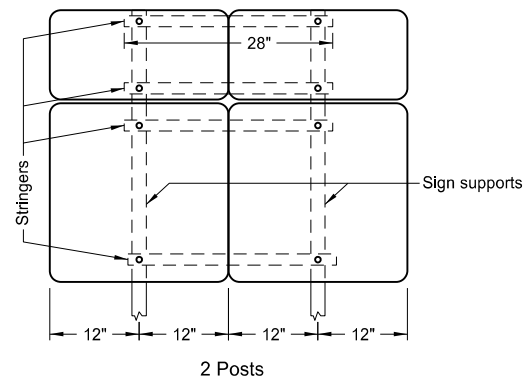
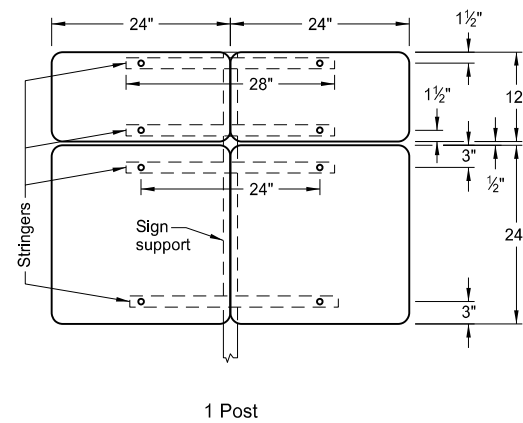
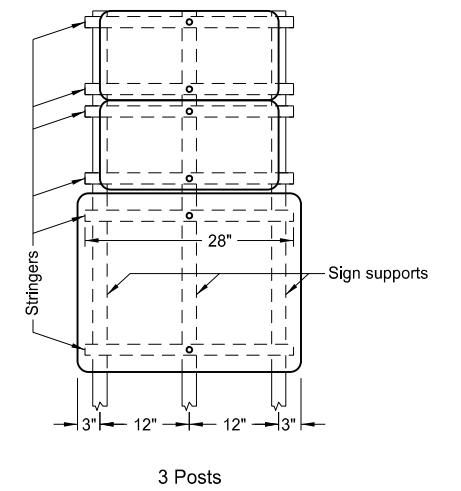

ASSEMBLY NO. 375

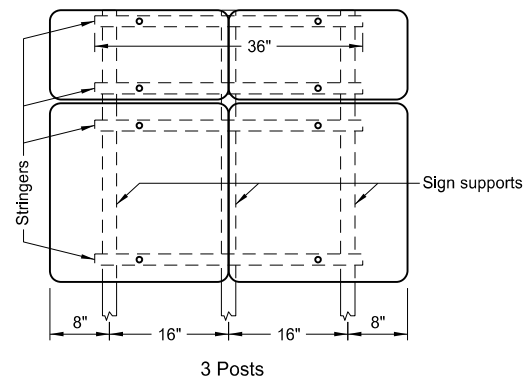

NORTH DAKOTA DEPARTMENT OF TRANSPORTATION	
8-22-12	
REVISIONS	
DATE	CHANGE
8-30-18	Updated notes to active voice.
9-04-19	New Design Engineer PE Stamp.

This document was originally issued and sealed by  
Kirk J Hoff,  
Registration Number  
PE- 4683,  
on 9/04/19 and the original document is stored at the North Dakota Department of Transportation