

SIGN PUNCHING, STRINGER AND SUPPORT LOCATION DETAILS  
REGULATORY, WARNING AND GUIDE SIGNS

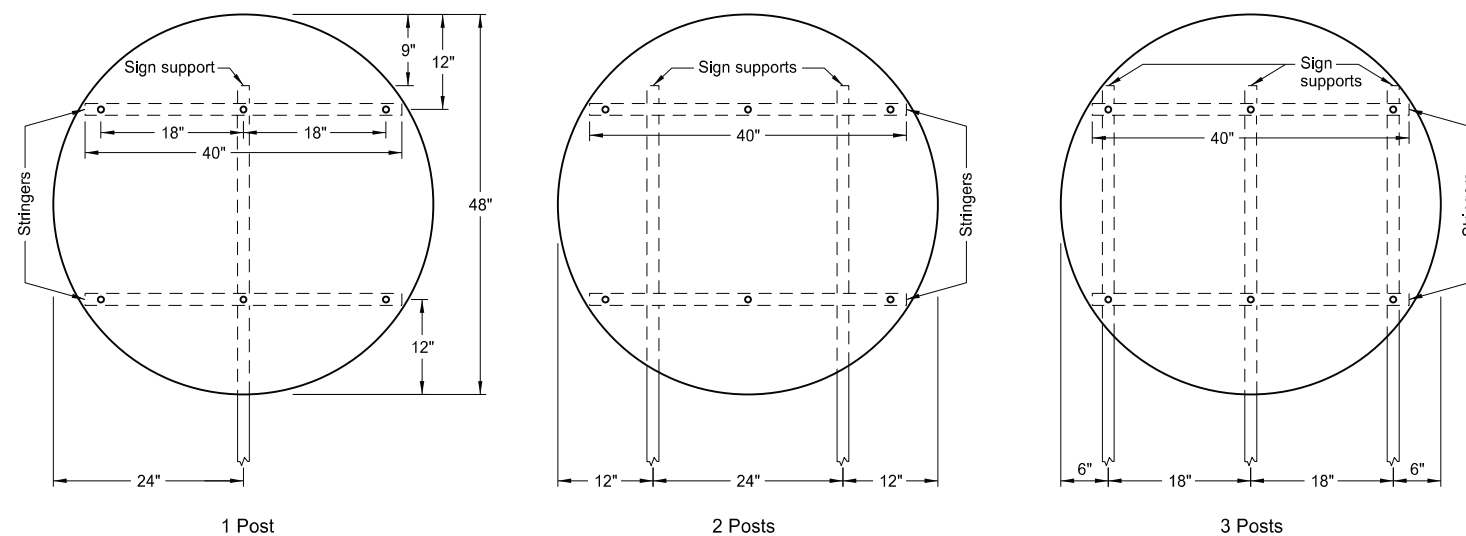

ASSEMBLY NO. 64

Notes:

1. Use 0.100 inch minimum thickness sign backing material.
2. Use 1½"x1½" perforated square tube stringers.
3. Punch holes round for ⅜" bolt.

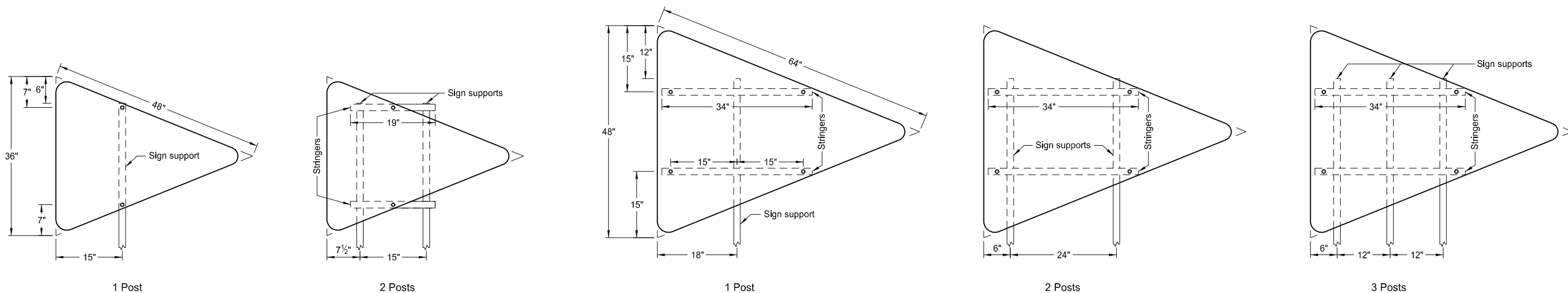

ASSEMBLY NO. 65

ASSEMBLY NO. 66

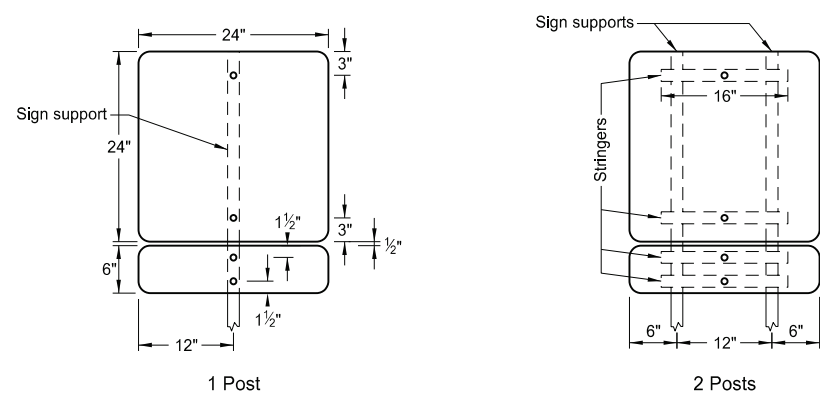

ASSEMBLY NO. 67

NORTH DAKOTA DEPARTMENT OF TRANSPORTATION	
8-22-12	
REVISIONS	
DATE	CHANGE
8-30-18	Updated notes to active voice.
8-30-19	New Design Engineer PE Stamp.
8-06-24	Electronic Stamp/Signature.

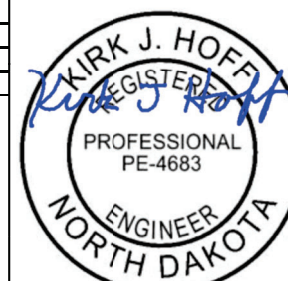

08/06/24