

SIGN PUNCHING, STRINGER AND SUPPORT LOCATION DETAILS
REGULATORY, WARNING AND GUIDE SIGNS

Notes:

1. Use 0.100 inch minimum thickness sign backing material.
2. Use 1½"x1½" perforated square tube stringers.
3. Punch holes round for ⅜" bolt.

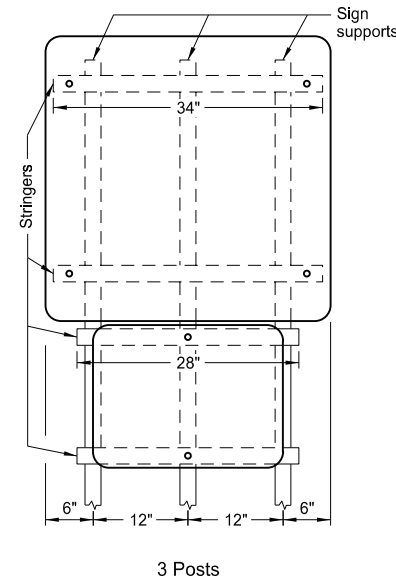
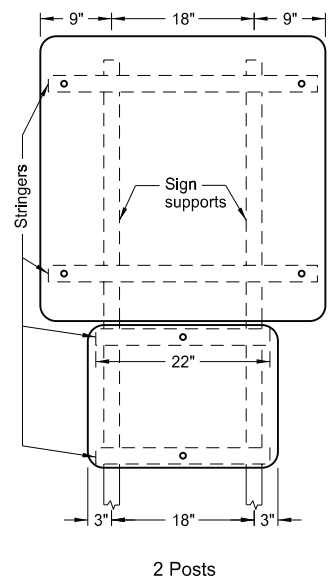
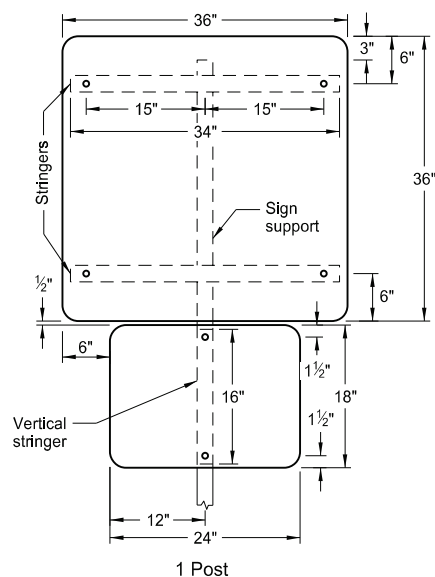

Assembly No. 44

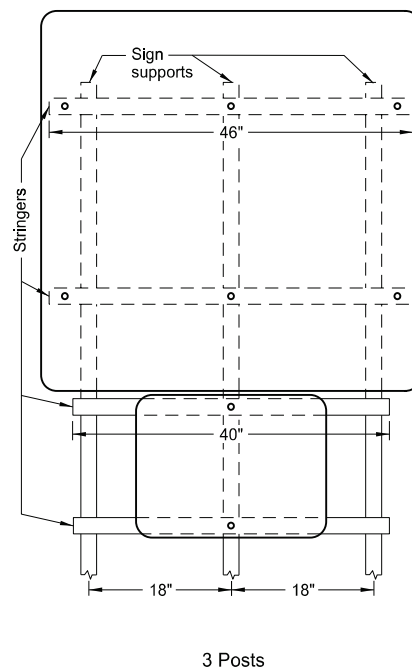
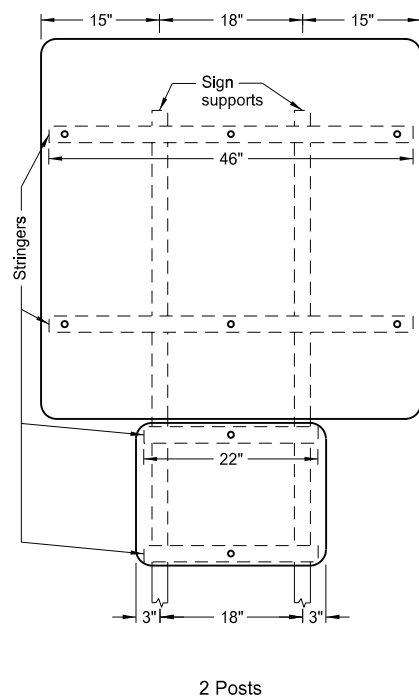
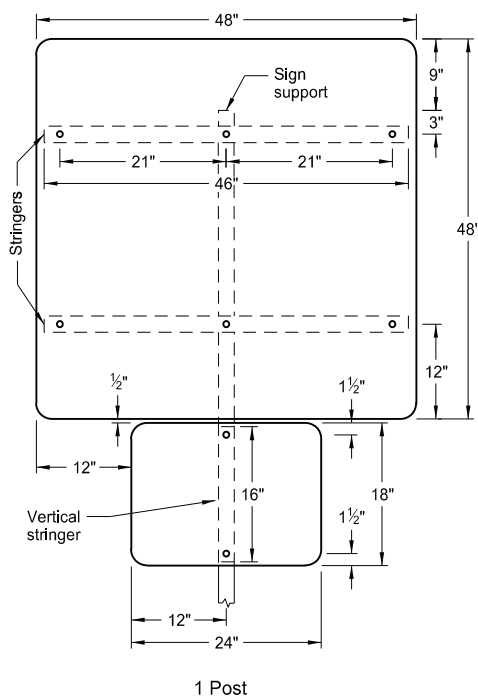

Assembly No. 45

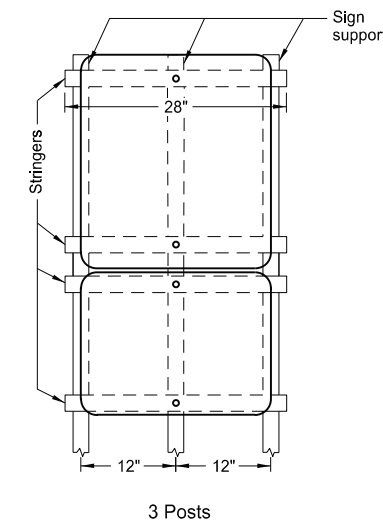
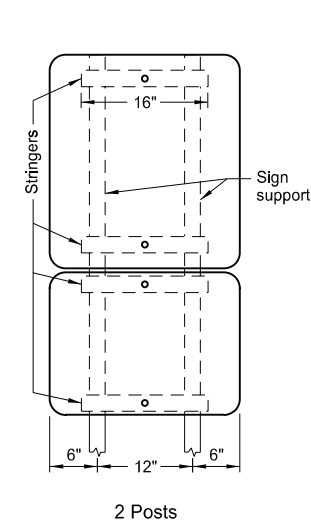
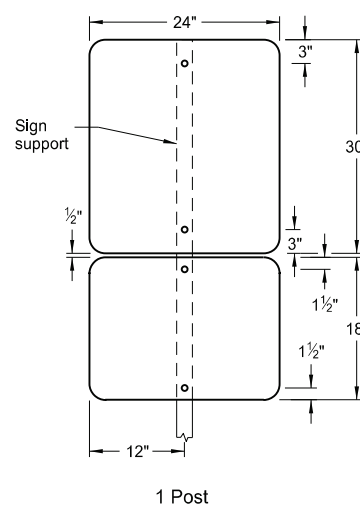

Assembly No. 46

NORTH DAKOTA DEPARTMENT OF TRANSPORTATION	
8-22-12	
REVISIONS	
DATE	CHANGE
8-30-18	Updated note to active voice.
8-30-19	New Design Engineer PE Stamp.
8-06-24	Electronic Stamp/Signature.



08/06/24