

ARROW DETAILS FOR LANE CONTROL AND ARROW-PER-LANE SIGNS

D-754-10

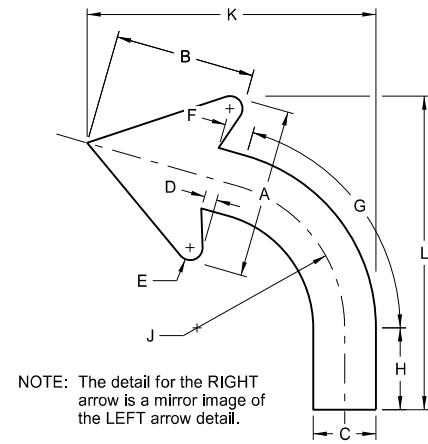

LEFT

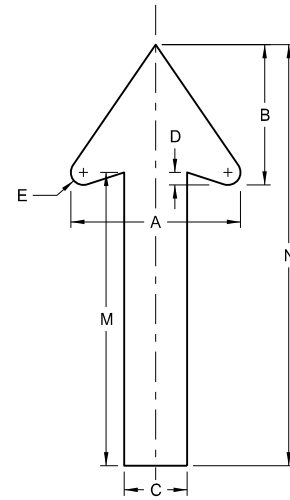

THRU

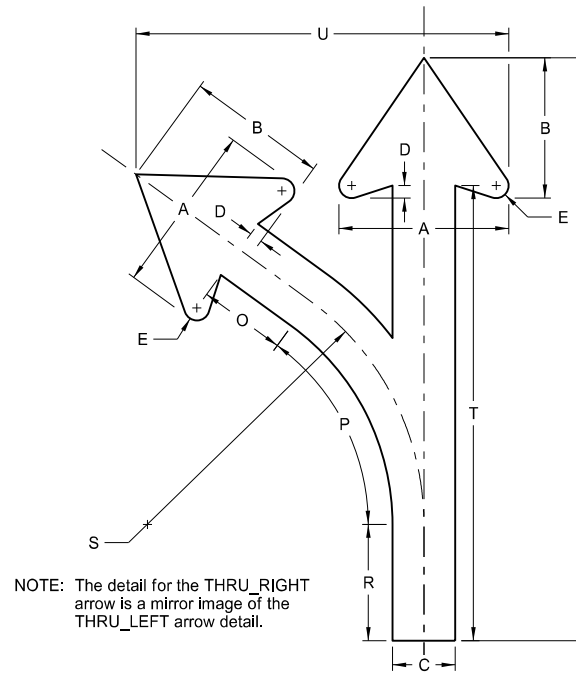

THRU\_LEFT

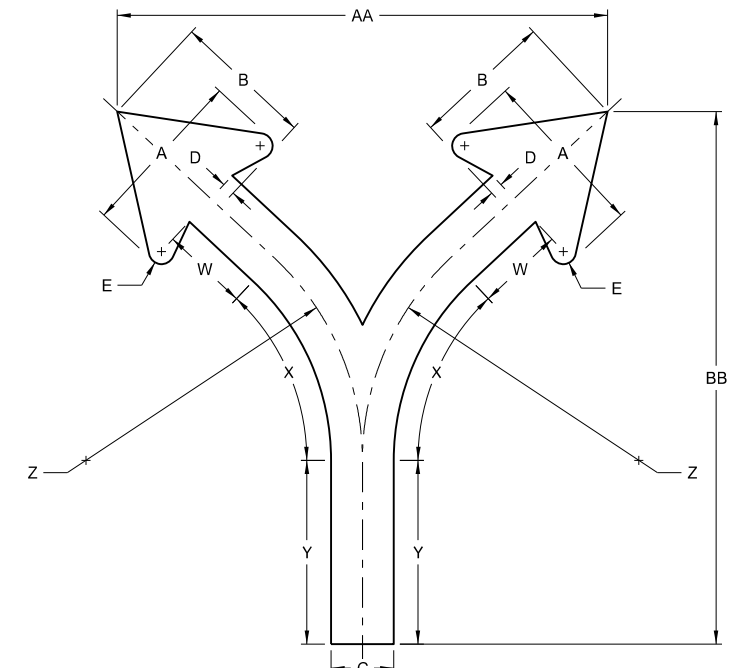

SPLIT

ADVANCE INTERSECTION CONTROL

DESIGNATION	A	B	C	D	E	F	G	H	J	K	L	M	N	O	P	R	S	T	U	V	W	X	Y	Z	AA	BB
ND_2.5IN	6.75"	5.563"	2.5"	0.5"	0.5"	1.140"	74°	3.279"	5.875"	11.468"	12.478"	13.687"	18.75"	3.480"	54°	4.642"	11"	18.125"	14.813"	23.188"	3.485"	47°	9.313"	11"	19.5"	23.188"
ND_3IN	8.126"	6.688"	3"	0.563"	0.563"	1.444"	74°	3.752"	7.731"	14.376"	15.487"	16.927"	23.052"	3.448"	54°	6.811"	13.2"	22.367"	17.232"	28.492"	3.508"	46°	12.305"	13.2"	21.92"	28.492"
ND_3.75IN	10.126"	8.375"	3.75"	0.75"	0.75"	1.679"	74°	4.889"	8.813"	17.202"	18.717"	20.5"	28.125"	5.195"	54°	6.960"	16.5"	27.157"	22.220"	34.782"	5.198"	47°	13.969"	16.5"	29.25"	34.782"

LANE-USE CONTROL

DESIGNATION	A	B	C	D	E	F	G	H	J	K	L	M	N	O	P	R	S	T	U	V	W	X	Y	Z	AA	BB
ND_4.5IN	12.126"	10"	4.5"	0.875"	0.875"	1.519"	72°	6.326"	11.4"	20.25"	23.418"	14.293"	23.418"	-	-	-	-	-	-	-	-	-	-	-	-	-

ARROW-PER-LANE

DESIGNATION	A	B	C	D	E	F	G	H	J	K	L	M	N	O	P	R	S	T	U	V	W	X	Y	Z	AA	BB
ND_7.75IN	21"	17.25"	7.75"	1.5"	1.5"	6.701"	66°	14.303"	20"	36.25"	45"	50.25"	66"	11.831"	68°	4.125"	31.875"	50.25"	56"	66"	0.127"	60°	8.190"	43.25"	70.75"	55"

NORTH DAKOTA DEPARTMENT OF TRANSPORTATION	
4-23-18	
REVISIONS	
DATE	CHANGE
8-29-19	New Design Engineer PE Stamp.

This document was originally issued and sealed by Kirk J Hoff, Registration Number PE- 4683, on 8/29/19 and the original document is stored at the North Dakota Department of Transportation