

### Hinge Plate, Fuse Plate and Foundation Details for Standard Pipe

Notes:  
 Fuse Joint Cuts - For steel posts cut after galvanizing, either galvanize cut after fabrication, or treat cut surface in accordance with ASTM A780. Aluminum posts need no treatment.

Use standard drawings D-754-2, D-754-3 and D-754-4 for information on breakaway base details.

Maintain the 4" vertical height and 60" diameter horizontal clearance of the break-away base at each post location.

- Assembly Procedure:
1. Assemble hinge plate to post with bolts and one flat washer and lock washer under nut.
  2. Tighten all bolts the maximum possible with 12" to 15" wrench.

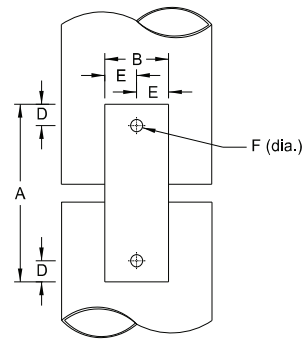

Hinge Plate

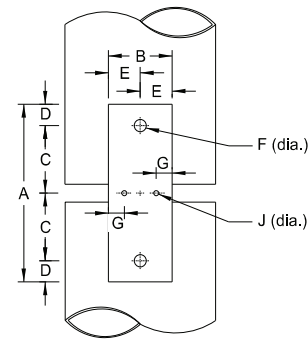

Perforated Fuse Plate

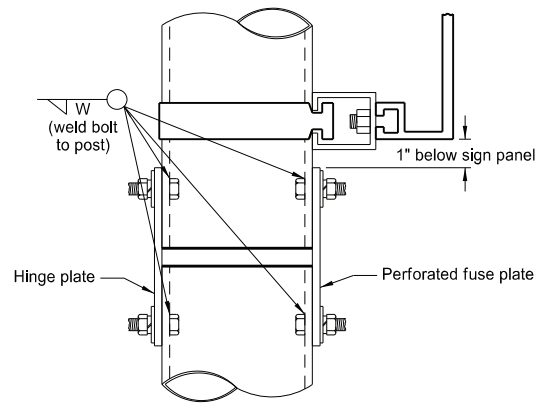

Side View

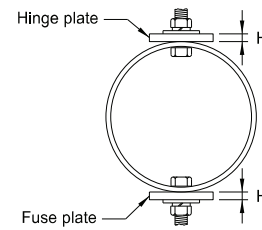

Top View

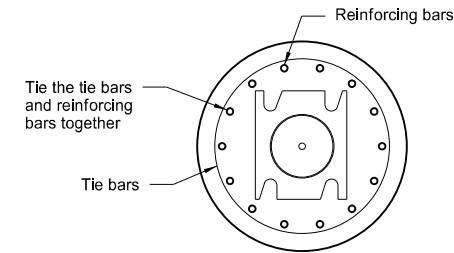

Top View  
 See standard drawing D-754-5 for size, number, and length of rebar. Use 3 bolt base plate for Type D.

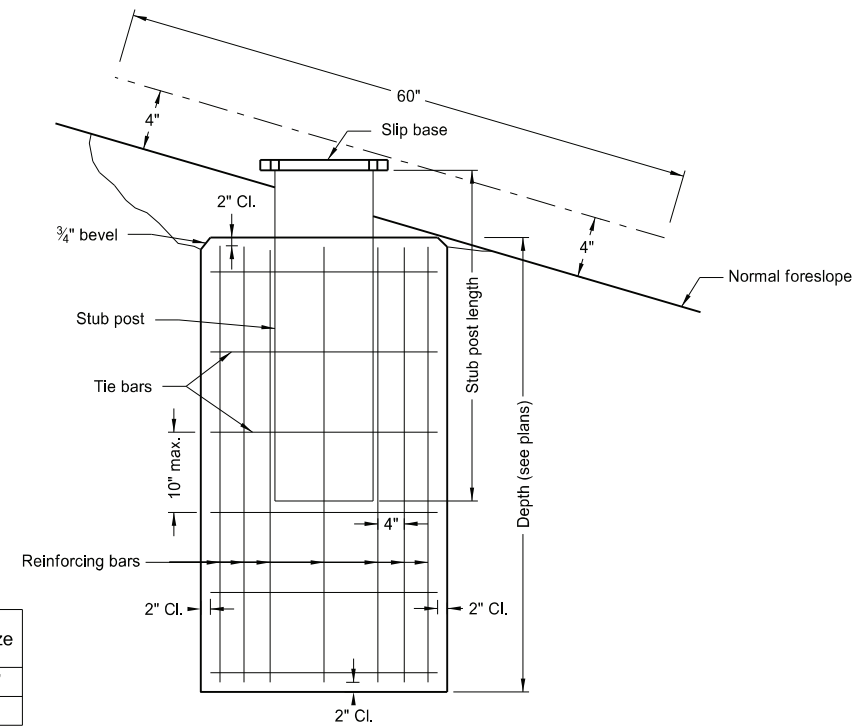

Foundation Front View  
 Foundation detail for breakaway base with stub post connection.

Foundation diameter	Post Size
1'-4"	3 1/2"-4"
1'-9"	5"-6"

Round Metal Posts							
Dimensions				Properties			
Nominal dia. in.	Outside dia. in.	Inside dia. in.	Wall Thickness in.	Weight per Foot Pound	Moment of Inertia in. <sup>4</sup>	Cross Sec. Area in. <sup>2</sup>	Section Diameter in. <sup>2</sup>
Steel							
3 1/2	4.000	3.548	.226	9.11	4.788	2.680	2.394
4	4.500	4.026	.237	10.79	7.233	3.174	3.215
5	5.563	5.047	.258	14.62	15.16	4.300	5.449
6	6.625	6.065	.280	18.97	28.14	5.581	8.495
Aluminum							
3 1/2	4.000	3.548	.226	3.151	4.788	2.680	2.394
4	4.500	4.026	.237	3.733	7.232	3.174	3.214
5	5.563	5.047	.258	5.057	15.16	4.300	5.451
6	6.625	6.065	.280	6.564	28.14	5.581	8.496

Nominal Pipe Size dia.	Fuse and Hinge Plate Data										
	Bolt Size	A	B	C	D	E	F	G	H	I	J
3 1/2"	1/2" x 1 1/2"	5"	1 3/4"	1 1/16"	1 3/16"	7/8"	9/16"	1 5/32"	1/4"	1 3/32"	7/16"
4"	5/8" x 1 1/2"	5 3/4"	2"	1 7/8"	1"	1"	1 1/16"	1 7/32"	3/8"	1 5/32"	9/16"
5"	5/8" x 1 3/4"	5 3/4"	2"	1 7/8"	1"	1"	1 1/16"	9/16"	1/2"	7/16"	5/8"
6"	3/4" x 2 1/4"	6 1/4"	2 1/4"	2"	1 1/8"	1 1/8"	1 3/16"	5/8"	1/2"	1/2"	5/8"

NORTH DAKOTA DEPARTMENT OF TRANSPORTATION	
2-28-14	
REVISIONS	
DATE	CHANGE
8-30-18	Updated notes to active voice.
8-29-19	New Design Engineer PE Stamp.
8-05-24	Electronic Stamp/Signature.



08/05/24