

CURB RAMP RETROFIT DETAILS

D-750-3

NOTES:

- Ramp width is the useable portion of the ramp, excluding flares. Match curb ramp width to Existing Pedestrian Facility (EPF) width (4' minimum or 5' for island ramps.) Match ramp width to existing shared use path width. Maximum ramp length is 15'.
- Provide turning space with desirable 5' x 5' size or larger and minimum 4' x 4' unconstrained size, for any change of direction. Provide landing 5' long x width of path at the bottom and top of parallel ramps and at the top of perpendicular ramps. Turning spaces and Landings may overlap.
- Match detectable warning panel width to ramp width. Radial panels are allowed. Place detectable warning panel within the lower turning space.
- Provide a continuous 4' minimum width EPF with 1.5% preferred cross slope and max 2% constructed cross slope.
- Modify existing ground slope with landscaping, as needed. If not possible, use a vertical curb as detailed on Standard D-750-2. The Engineer will measure curb at the unit price bid for "Curb - Type I" per lineal foot.
- Islands: If the profile of the island curb ramp is 2% or less, provide a minimum distance of 2' between warning panels. If the profile of the island curb ramp is steeper than 2%, provide a turning space between the ramps.
- Provide generally planar vertical alignments. Provide grade breaks, perpendicular to the direction of the pedestrian travel, at the top and bottom of curb ramps (1.5% preferred, 2% max constructed cross slope).
- See Curb Ramp Retrofit Details Standard D-750-4 for additional information. Also See PROWAG for full compliance in the curb ramp area.
- Grade transitions shall be flush.

LEGEND:

- : Detectable Warning Panel.
 - : Landscaping.
 - : Transitional tie-in to nearest joint, if needed.
 - : Curb Ramp Retrofit Transitional Area (See Standard Drawing D750-4)
 - : 4' long x width of EPF or 4' minimum Clear space outside traffic lanes of travel. 1.5% preferred cross slope 2% maximum cross slope 4.7% preferred running and counter slope 5% maximum running and counter slope
 - : Turning Space Use at top of ramp or when changing directions. 1.5% preferred slope (2% maximum) all directions.
 - : Preferred Ramp Grade = 5% to 7.5%. Maximum Constructed Grade = 8.3%. Preferred Cross Slope = 1.5%. Maximum Constructed Cross Slope = 2%.
 - : 1.5% preferred cross slope 2% maximum constructed cross slope running slope consistent with the EPF 4.7% preferred max counter slope 5.0% max constructed counter slope
 - : 10:1 maximum constructed slope.
 - : 4:1 maximum constructed slope.
- 0", 3", or 6" : Curb Height.

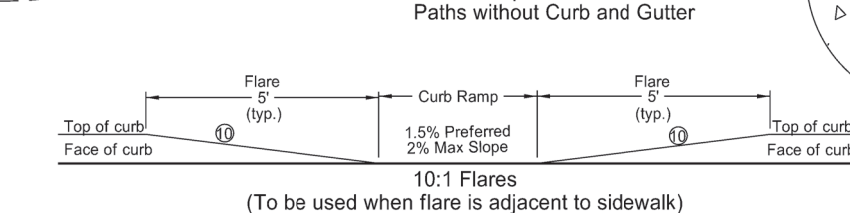
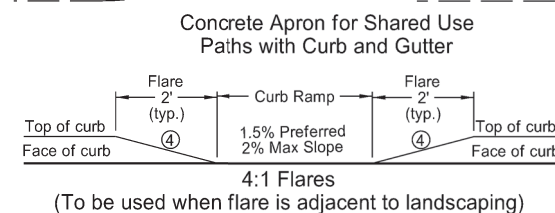
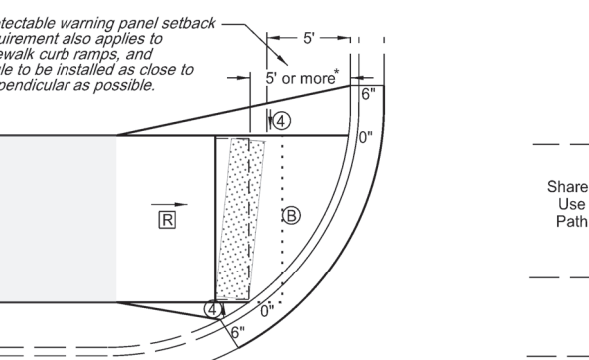
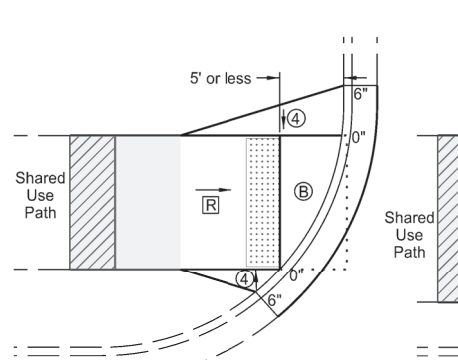
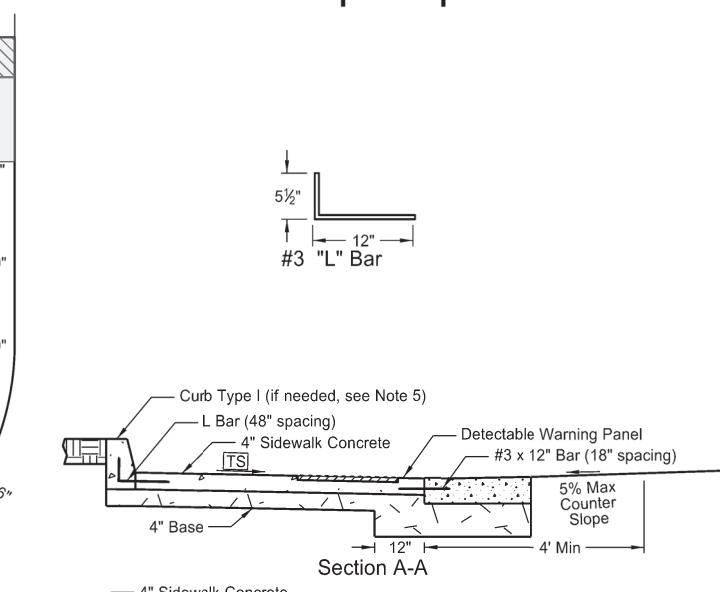
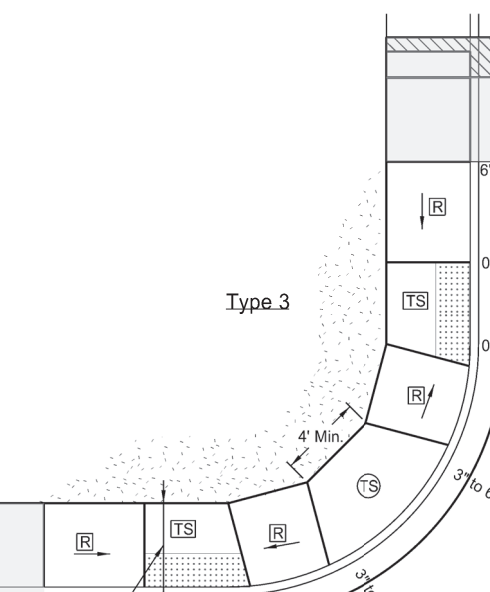
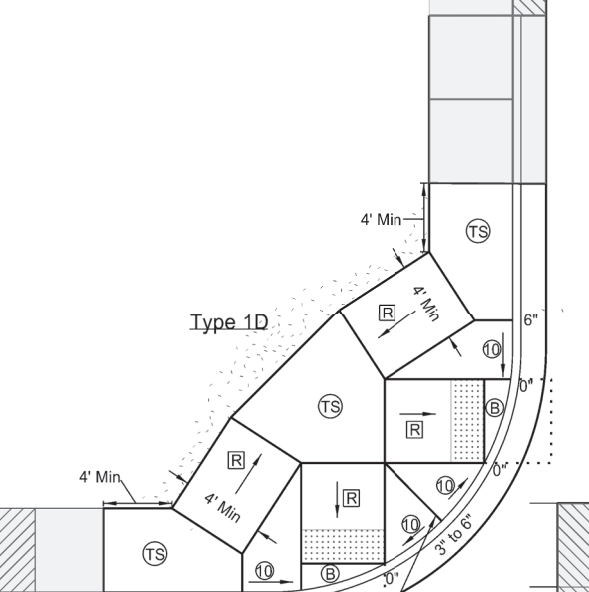
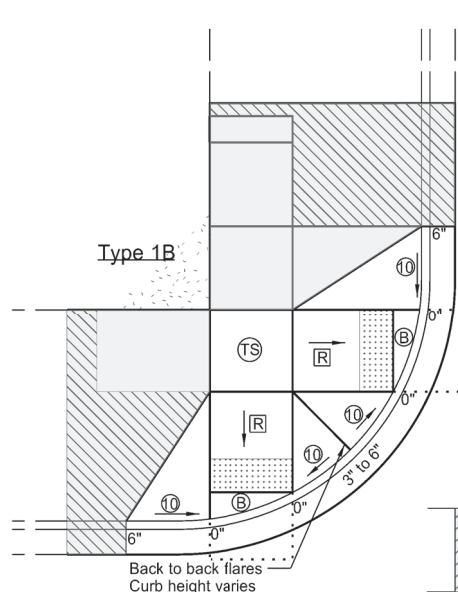
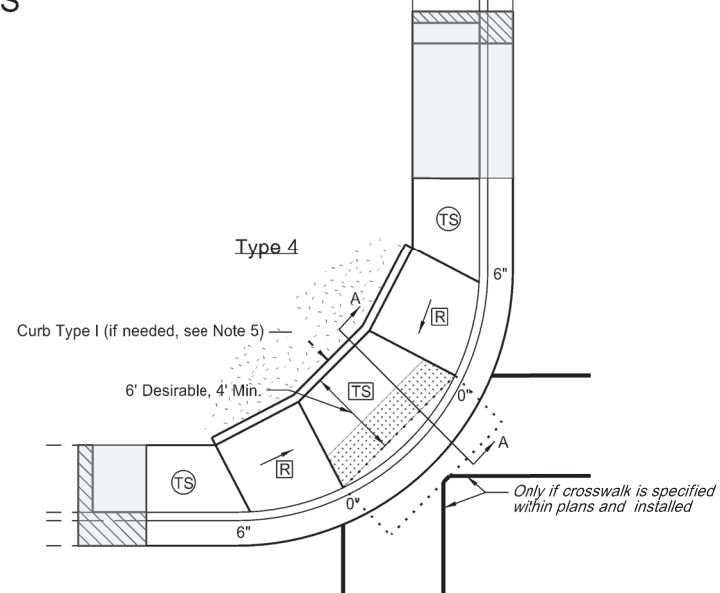
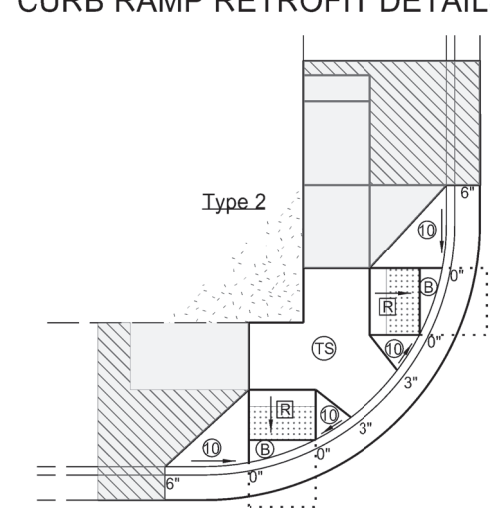
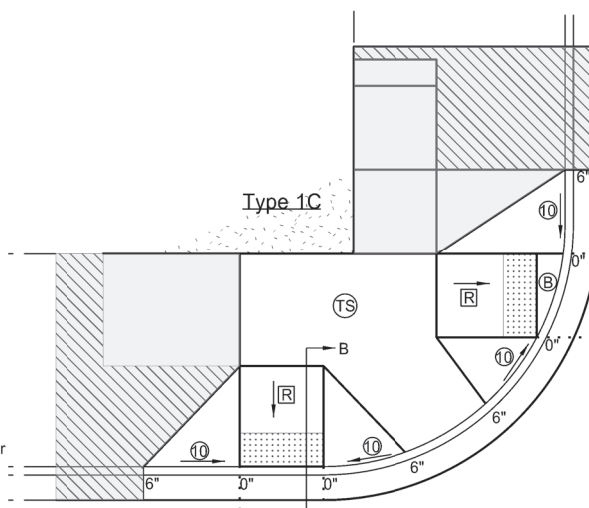
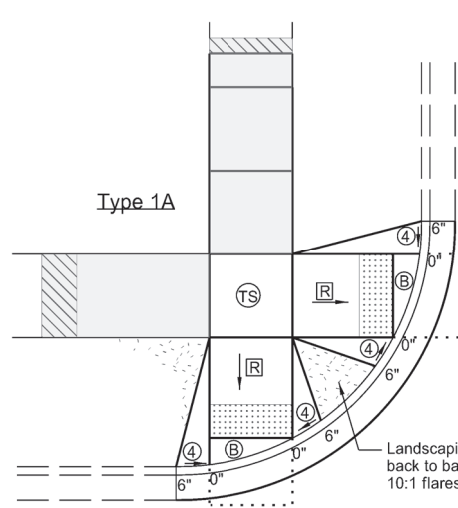

Median Refuge Islands (Cut-Through)

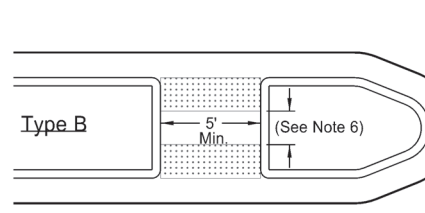
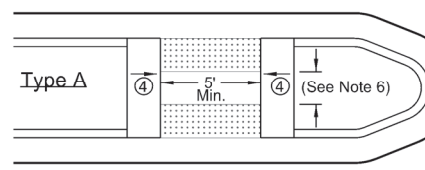

NORTH DAKOTA DEPARTMENT OF TRANSPORTATION	
11-26-13	
REVISIONS	
DATE	CHANGE
10-17-17	Updated to active voice.
09-05-18	Revised Notes, Revision for Turning Space, Added Passing Space Requirements, Turned Detectable Warning Panel
03-15-21	Slope & other clarifications.
05-19-21	Separate Curb Ramp Transition Area from Curb Ramp area

