

PRECAST CONCRETE MEDIAN DRAIN

D-722-7

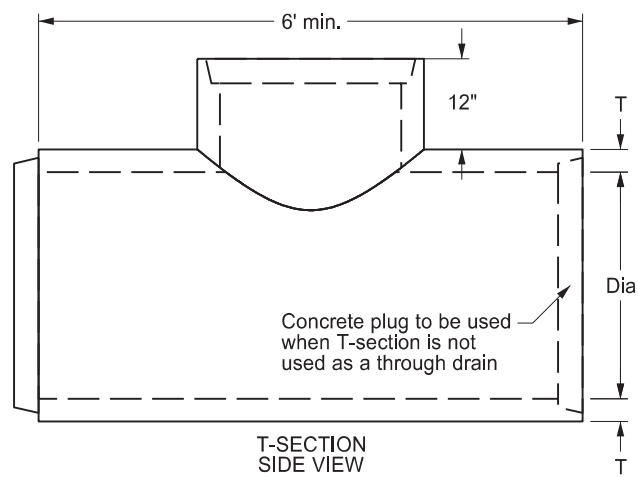

Dia = Diameter of drainage pipe
T = Wall thickness of drainage pipe

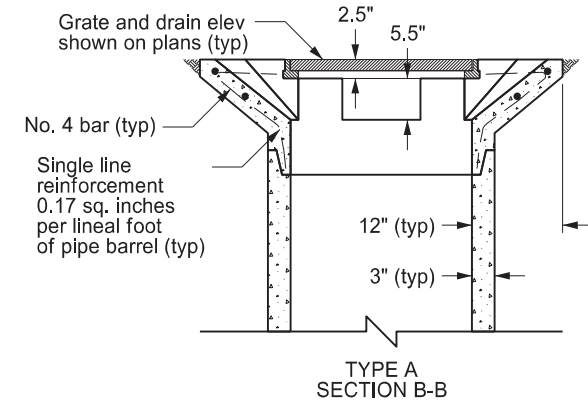
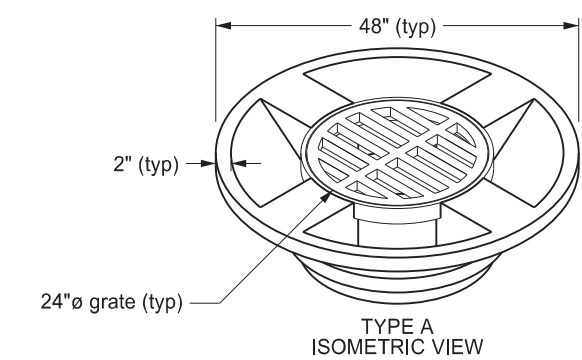
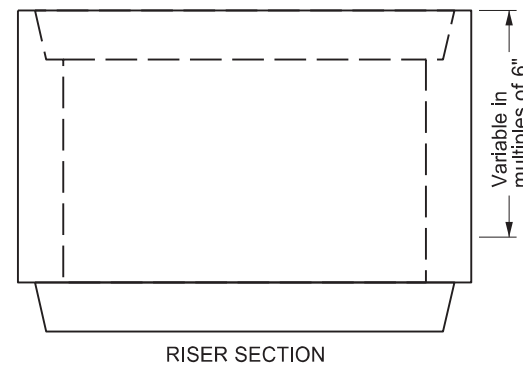
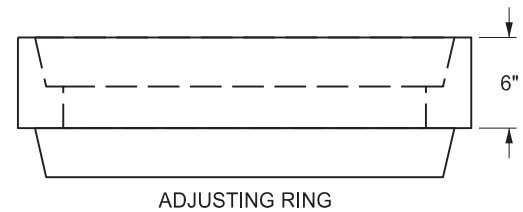
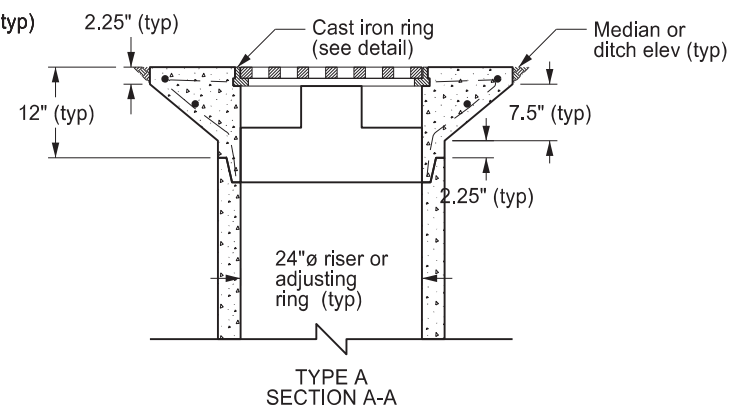
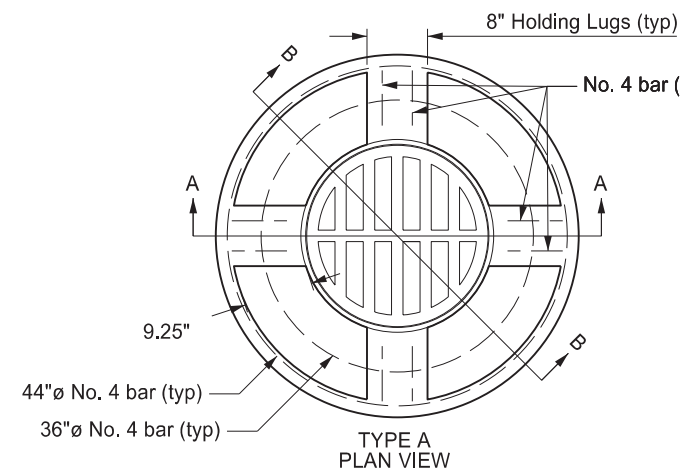
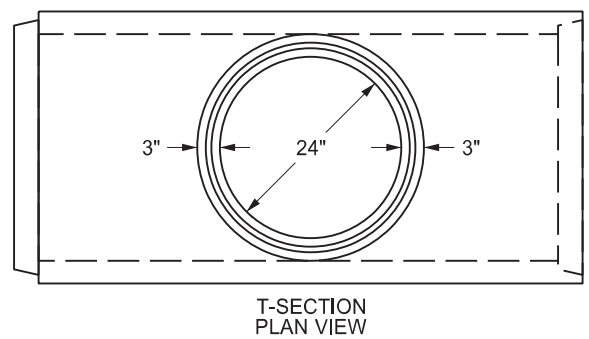
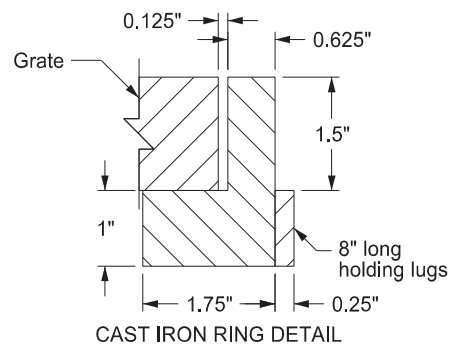
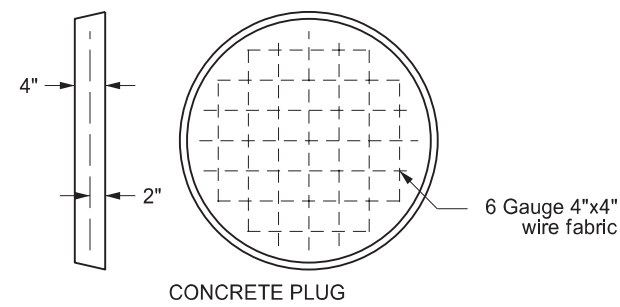

Notes:

1. Use Neenah R-4370-23G, East Jordan 1117 grate, or equal with a minimum waterway of 0.85 SF. If modifications to the drain are required to facilitate similar castings, obtain written approval from the Engineer.
2. Use castings manufactured in accordance with AASHTO M 306. Use castings comprised of metal that conforms to AASHTO M 105, Class 35B.
3. Use precast concrete median drains, adjusting rings, and riser sections that have been constructed in accordance with AASHTO M 199. Use T-sections constructed in accordance with AASHTO M 170.
4. Use only Grade 60 reinforcing steel. For adjusting rings, riser sections, and T-sections, use reinforcing that meets AASHTO M 170.
5. Include the cost of furnishing and installing the castings and drains in the price bid for "Median Drain Precast Concrete-Type A". Include the cost of furnishing and installing the adjusting rings and riser sections shall in the price bid for "Pipe Conc Reinf 24IN (CL_)". Include the cost of furnishing and installing the T-sections and concrete plugs in the price bid for "Pipe Conc Reinf (_ IN) (CL_)".
6. Seal all joints with rubber gaskets or with sealer approved by the engineer.

NORTH DAKOTA DEPARTMENT OF TRANSPORTATION	
6-30-14	
REVISIONS	
DATE	CHANGE
8-6-21	Notes 1-5

