

EROSION AND SILTATION CONTROLS  
MEDIAN OR DITCH INLET PROTECTION

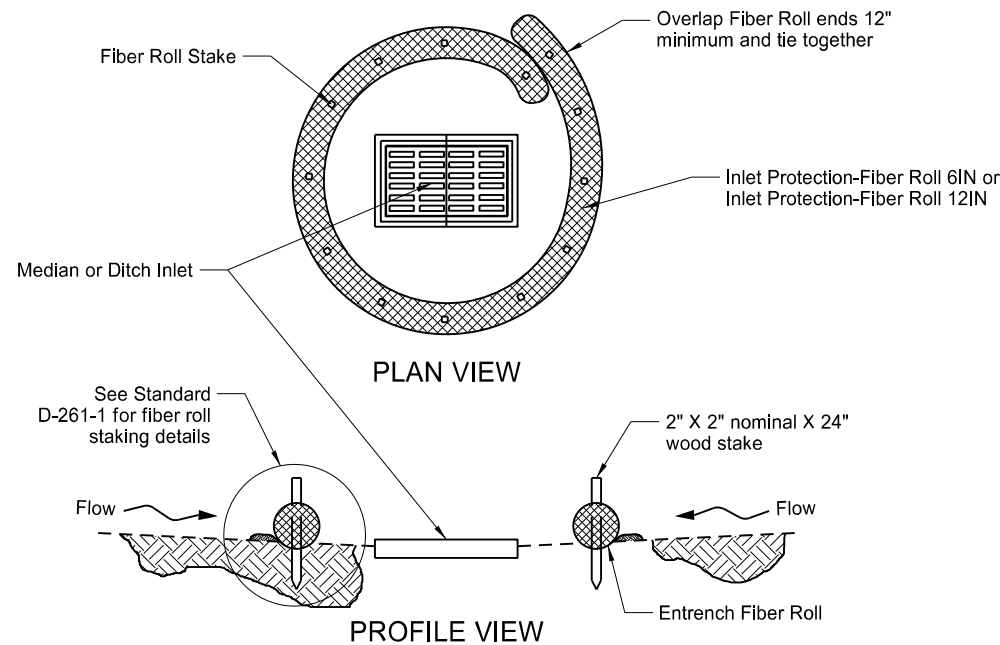

FIBER ROLL PROTECTION  
(MEDIAN OR DITCH INLET)

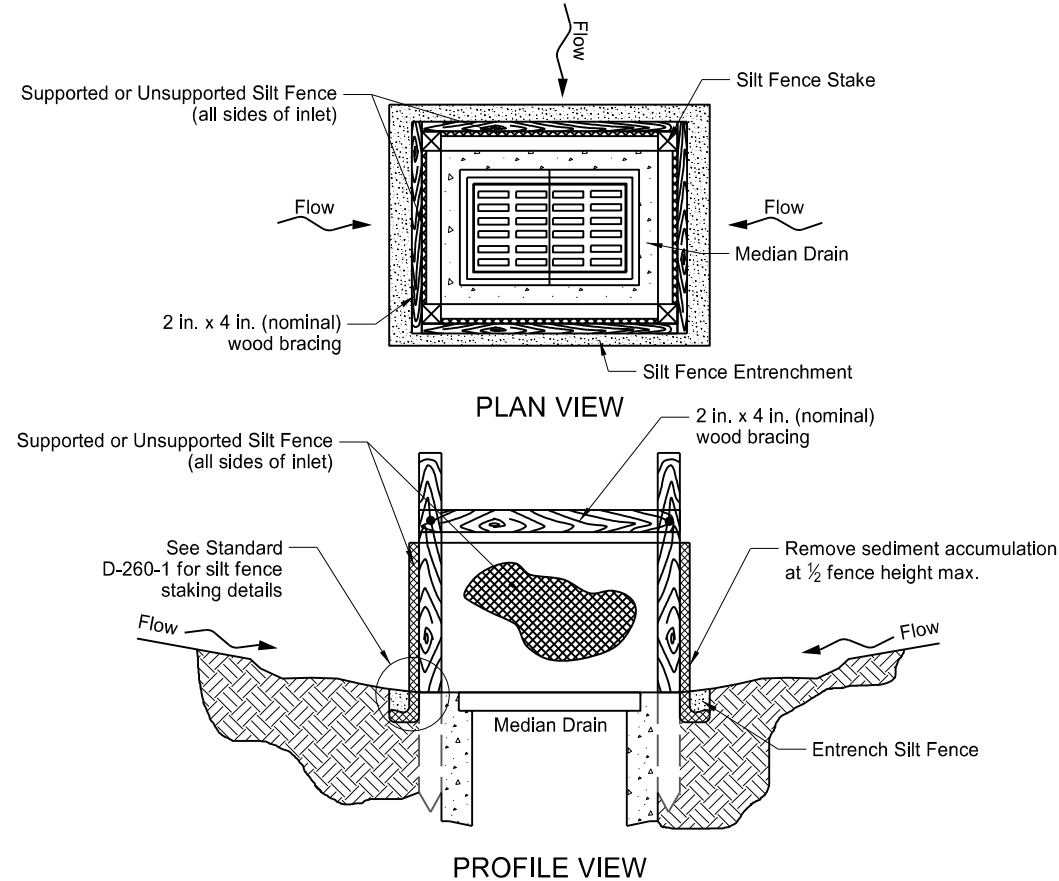

SILT FENCE PROTECTION  
(MEDIAN OR DITCH INLET)

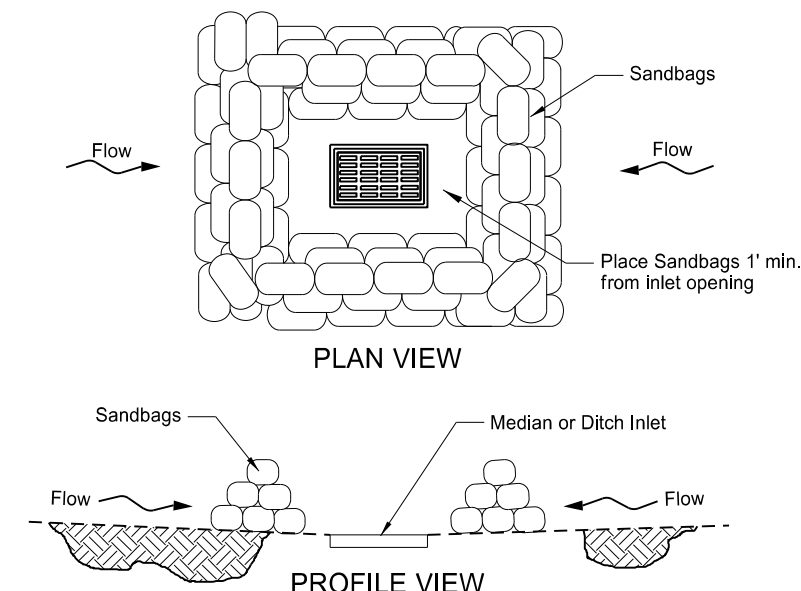

SANDBAG PROTECTION  
(LOW POINT)

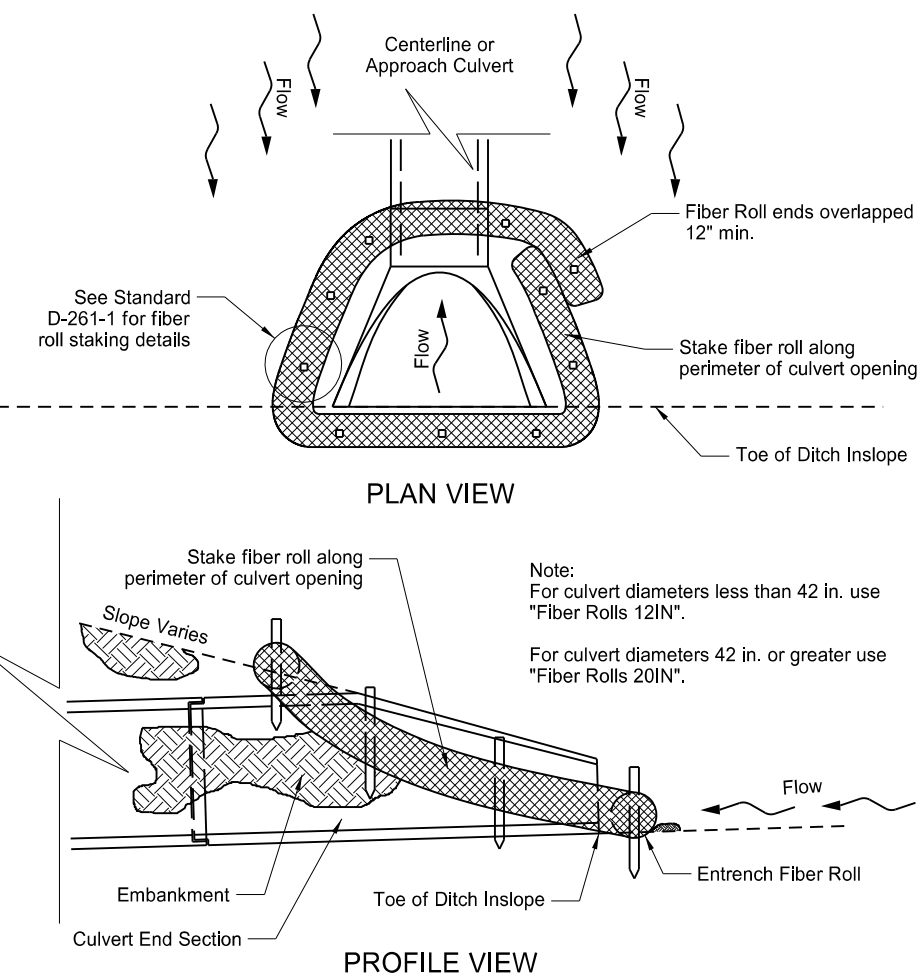

FIBER ROLL PROTECTION  
(INLET OF CULVERT)

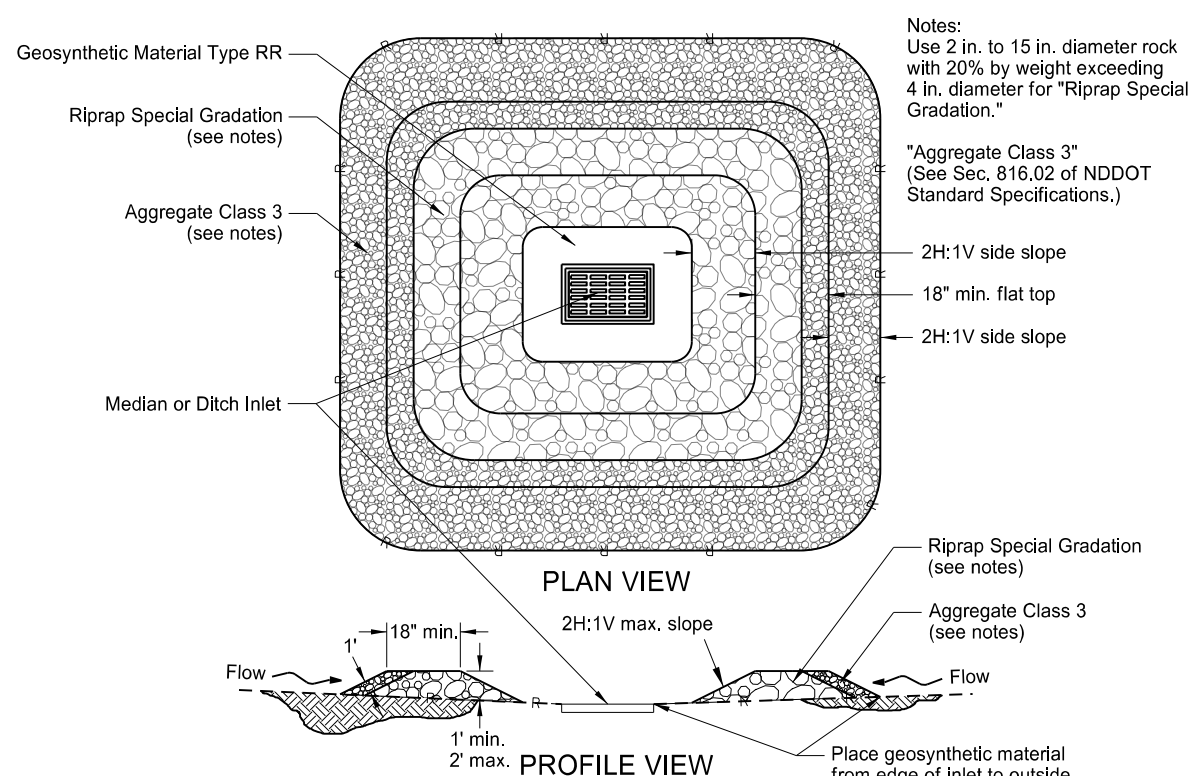

GRAVEL INLET PROTECTION  
(MEDIAN OR DITCH INLET)

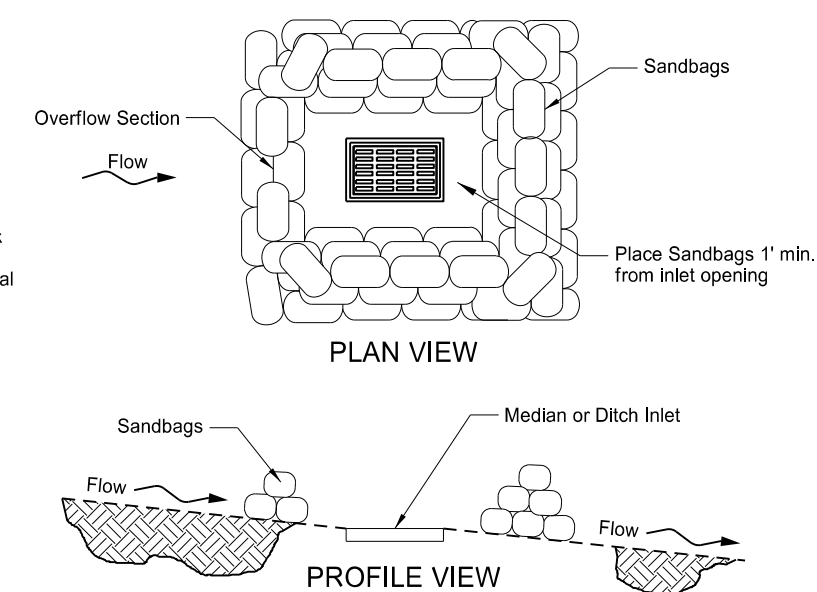

SANDBAG PROTECTION  
(ON SLOPE)

Notes:  
Use 2 in. to 15 in. diameter rock with 20% by weight exceeding 4 in. diameter for "Riprap Special Gradation."  
"Aggregate Class 3"  
(See Sec. 816.02 of NDDOT Standard Specifications.)

NORTH DAKOTA DEPARTMENT OF TRANSPORTATION	
10-03-13	
REVISIONS	
DATE	CHANGE
06-26-14	Updated reference to standard drawing number for fiber roll staking details.
10-01-14	Updated reference to standard drawing number for silt fence.
10-17-17	Updated to active voice.
08-27-19	New Design Engineer PE Stamp.

This document was originally issued and sealed by  
Kirk J Hoff,  
Registration Number  
PE- 4683,  
on 8-27-19 and the original document is stored at the North Dakota Department of Transportation