

### CONSTRUCTION SIGNING MEDIAN CROSSOVER

D-704-45

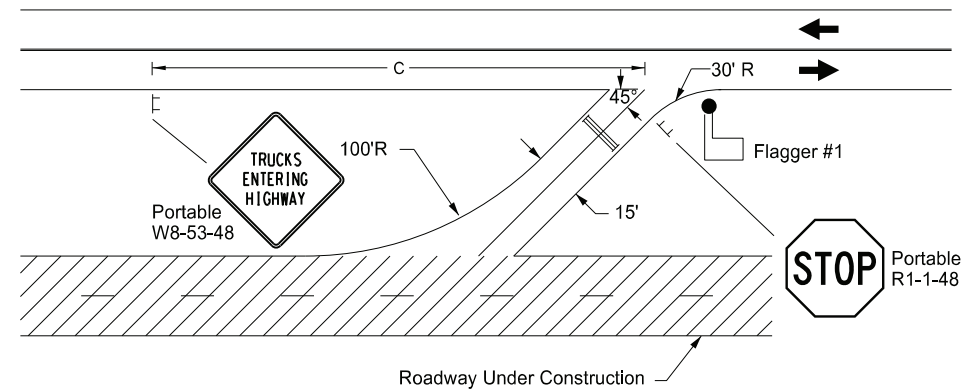

TRUCKS ENTERING ROADWAY  
(ADT 2000 or Less)

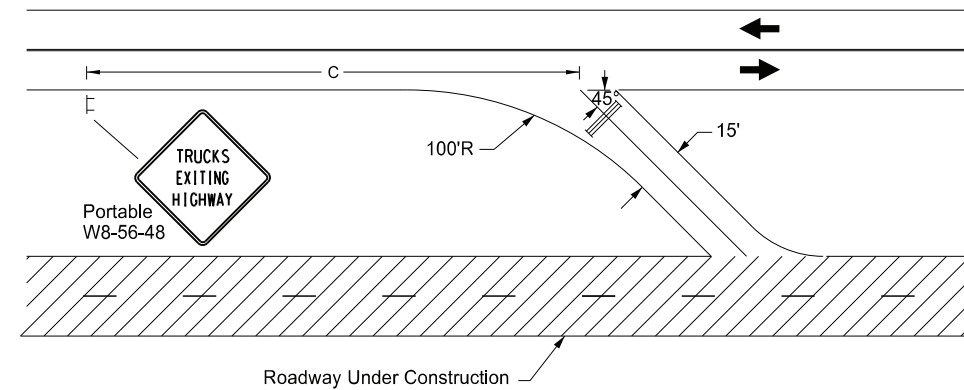

TRUCKS EXITING ROADWAY

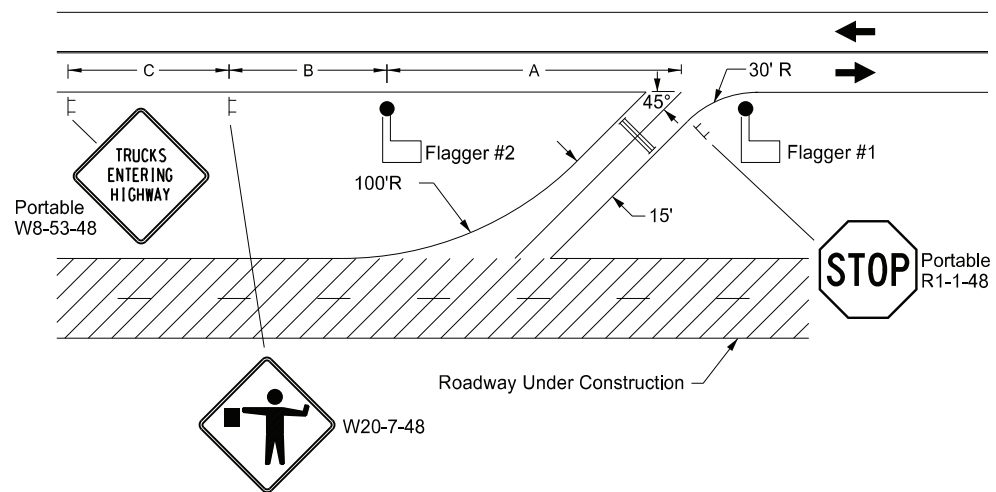

TRUCKS ENTERING ROADWAY  
(ADT Over 2000 )

**NOTES:**

1. Do not use Flagger #1 to slow interstate traffic. Flagger #1 is intended to assist truck driver in viewing oncoming traffic for truck's safe entry into traffic.
2. For ADT over 2000, use Flagger #2 to slow, but not stop, interstate traffic for trucks entering traffic.
3. Install barricades on median access when not in use. Place barricades at 45 degrees away from approaching traffic.
4. Do not stop exiting vehicles on roadway carrying traffic.

**KEY**

- Type III Barricade
- Sign
- Work Area
- Flagger

Road Type	ADVANCE WARNING SIGN SPACING		
	Distance Between Signs Min. (FT)		
	A	B	C
Urban - Low Speed (30 mph or less)	150	150	150
Urban - Low Speed (Over 30 mph to 40 mph)	280	280	280
Urban - High Speed (Over 40 mph to 50 mph)	360	360	360
Rural - High Speed (Over 50 mph to 65 mph)	720	720	720
Urban Expressway and Freeway (55 mph to 60 mph)	850	1350	2200
Rural Expressway and Freeway	1000	1500	2640
Interstate/4-Lane Divided (Maintenance and Surveying)	750	1000	1500

NORTH DAKOTA DEPARTMENT OF TRANSPORTATION	
11-19-12	
REVISIONS	
DATE	CHANGE
06-19-14	Deleted sign W16-2-24.
09-27-17	Updated to active voice.
11-01-19	New Design Engineer PE Stamp
08-02-24	Electronic Stamp/Signature



08/02/24