

LANE CLOSURES ON URBAN STREETS LAYOUTS

- Notes
- For Type V: Work on one side of roadway at a time so as not to block off more than one lane of traffic.
 - When parking is present, place signs so they are entirely visible above parked vehicles or at the edge of the parking area so they are visible to oncoming traffic. Place signs on portable mounts when located on roadway.
 - Place cones for tapering traffic at 3 equal spaces and cones for tangents at dimension "S". "S" = the numerical value of speed limit.
 - Re-establish speed limit. Determine exact speed limit in the field, dependent on location and conditions.
 - Determine the reduced speed limit based on the in-place speed limit before construction. Where speed reductions exceed 30 mph, install a second speed limit sign with the desired speed reduction (not to exceed 30 mph.) Place the second speed limit sign at 1/2 B.
 - Install flags on warning signs in urban areas when signs are not portable. Mount 24 inches square flags perpendicular to the edges of the sign, and at such a distance above the edge that the flag does not touch the sign when limp.
 - Cover existing speed limit signs within reduced speed zones.
 - Engineer to determine safe speed, when necessary.
 - As an option, use portable sign supports in lieu of post mounted signs in accordance with NDDOT Standard Drawing D-704-14.
 - Signs G20-55-96 and R2-1aP-24 are not required for urban projects.

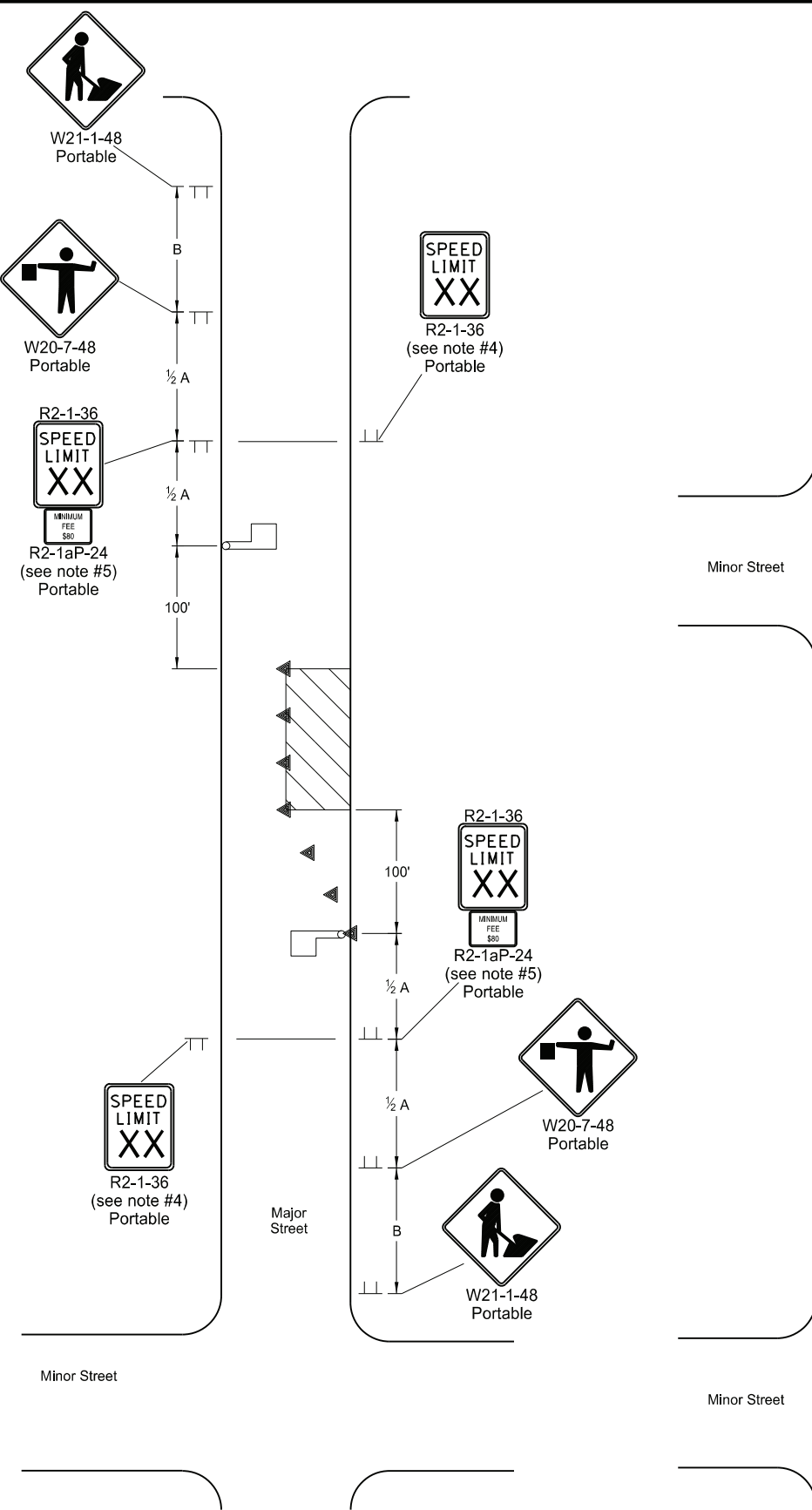

TYPE V
LANE CLOSURE ON URBAN STREET
Portion of roadway closed to traffic only during daylight hours (mid block location).

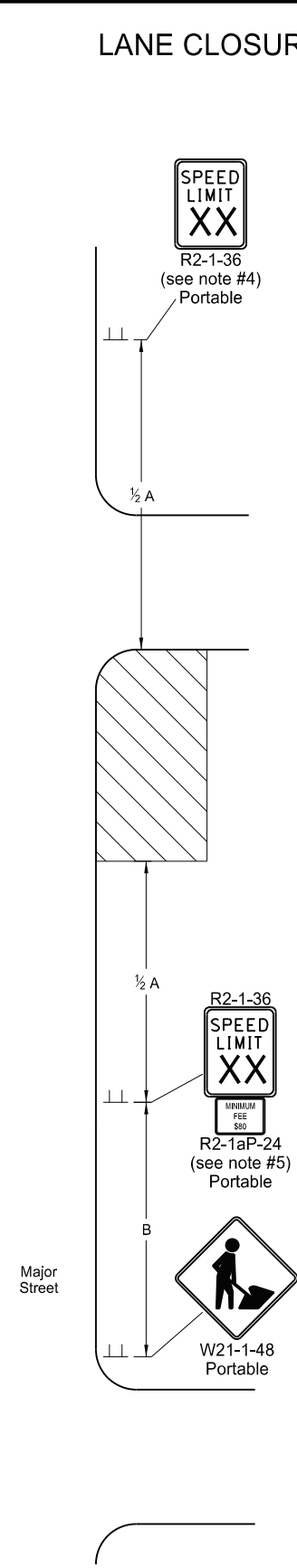

TYPE W
WORK BEYOND CURB ON URBAN STREET
Work area outside driving lane and no closure necessary.

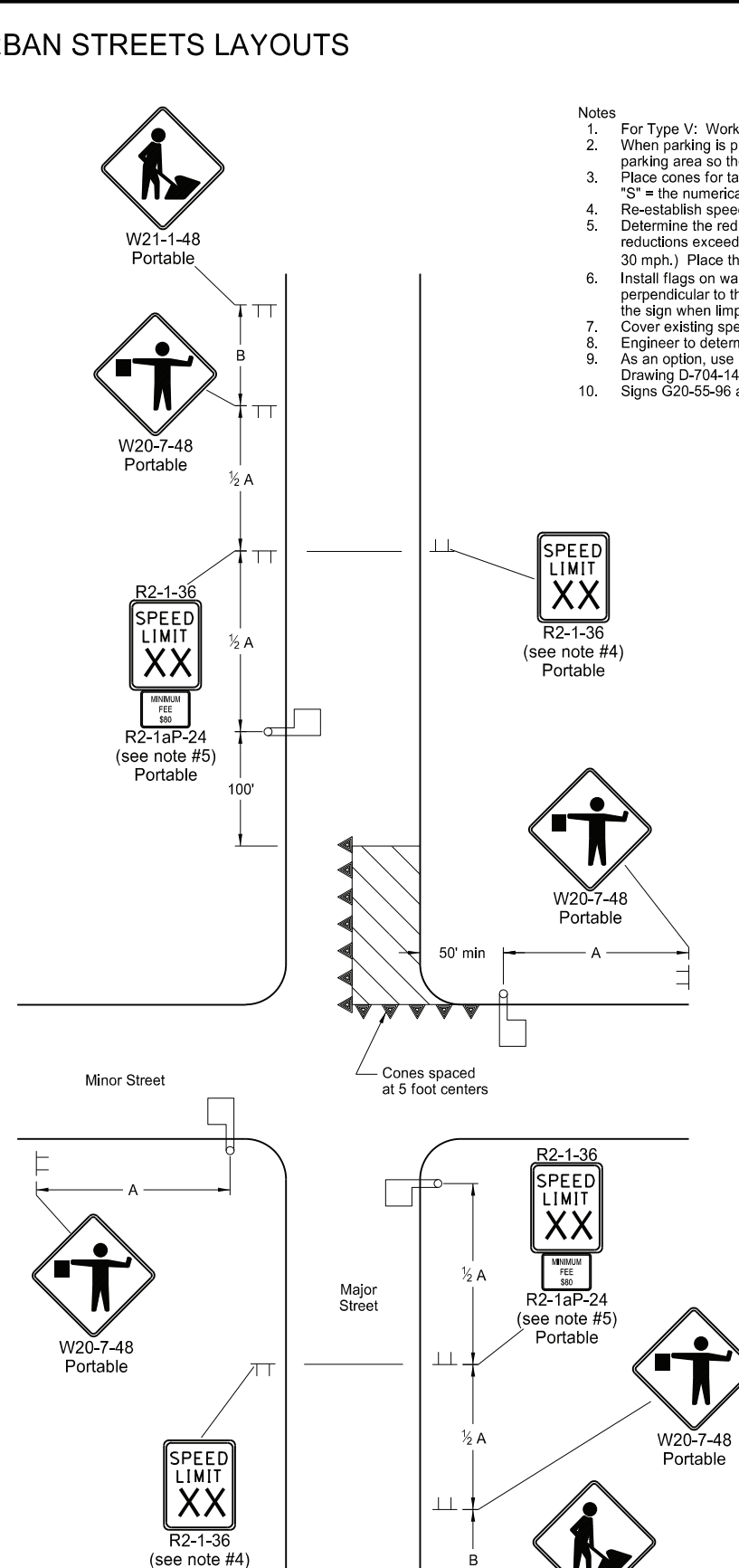

TYPE X
LANE CLOSURE NEAR INTERSECTION ON URBAN STREET
Portion of roadway closed to traffic only during daylight hours (end block location).

Road Type	Distance Between Signs Min. (ft)		
	A	B	C
Urban - Low Speed (30 mph or less)	150	150	150
Urban - Low Speed (over 30 to 40 mph)	280	280	280
Urban - High Speed (over 40 mph to 50 mph)	360	360	360
Rural - High Speed (over 50 mph to 65 mph)	720	720	720
Urban Expressway and Freeway (55 mph to 60 mph)	850	1350	2200
Rural Expressway and Freeway (70 mph to 75 mph)	1000	1500	2640
Interstate/4-Lane Divided (Maintenance and Surveying)	750	1000	1500

KEY	
	Sign
	Work area
	Cones
	Flagger

NORTH DAKOTA DEPARTMENT OF TRANSPORTATION	
REVISIONS	
DATE	CHANGE
8-17-17	Updated notes & removed signs
11-01-19	Revised note & added Min Fee sign
8-01-24	Electronic Stamp/Signature



08/01/24