

LANE MARKERS
(Spotting Tab for Seal Projects only)

Notes:

1. Install lane line markers as shown, prior to beginning the seal coat.
2. Attach cover to vertical part of marker so traffic does not cause it to detach, but it can be easily removed manually.
3. Remove protective covers immediately after seal coat is applied.
4. Remove markers after permanent pavement marking is installed.
5. Use marker body and cover manufactured from polyurethane material.
6. Marker types:
 Type Y - Yellow body and cover with yellow reflective tape on both sides.
 Type W - White body and cover with white reflective tape on one side.
7. Use retroreflective tape with a minimum reflectance of 1200 candle power per foot-candle per square foot, using a .1 degree observation angle and 0 degree entrance angle.
8. Use adhesive conforming to AASHTO M 237.

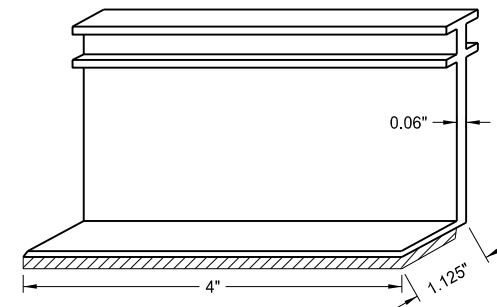
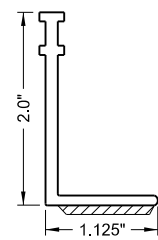

Marker Body

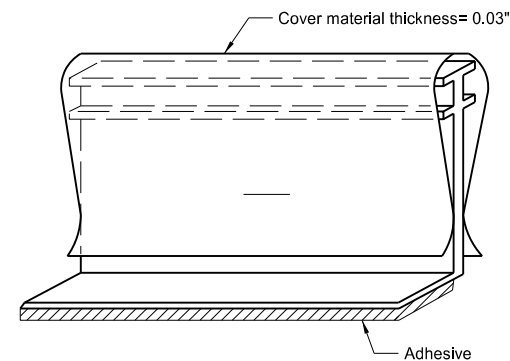
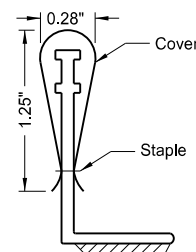

Marker Body with Protective Cover

NORTH DAKOTA DEPARTMENT OF TRANSPORTATION	
10-3-13	
REVISIONS	
DATE	CHANGE
9-27-17	Updated to active voice
10-03-19	New Design Engr PE Stamp

This document was originally issued and sealed by
 Kirk J Hoff,
 Registration Number
 PE- 4683,
 on 10/03/19 and the original document is stored at the
 North Dakota Department
 of Transportation