

TRANSVERSE EXPANSION JOINT DETAIL

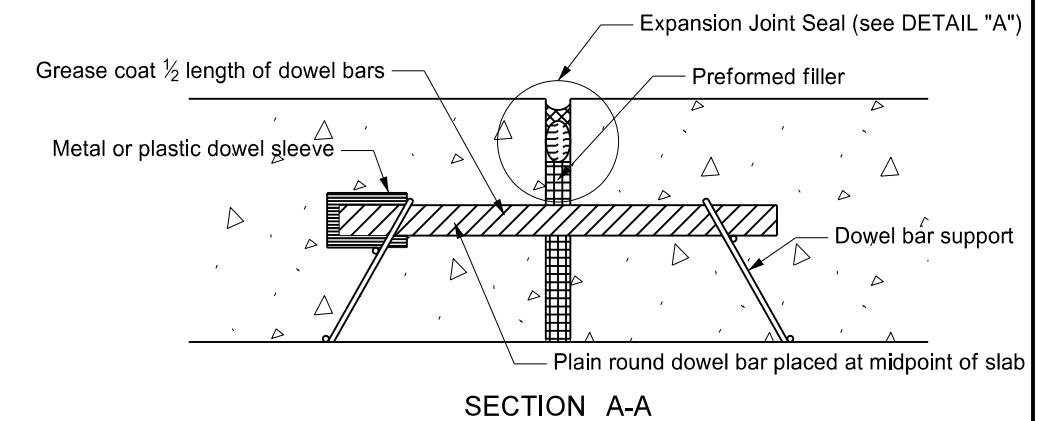
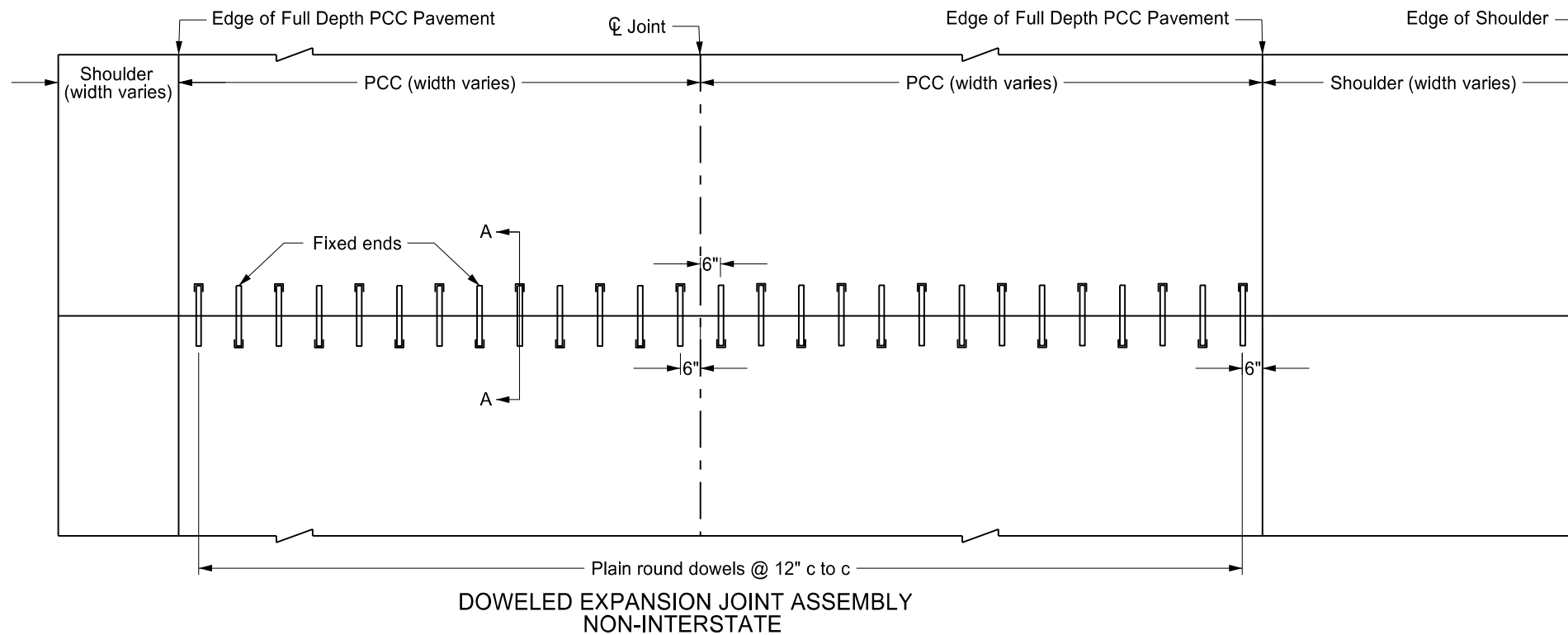
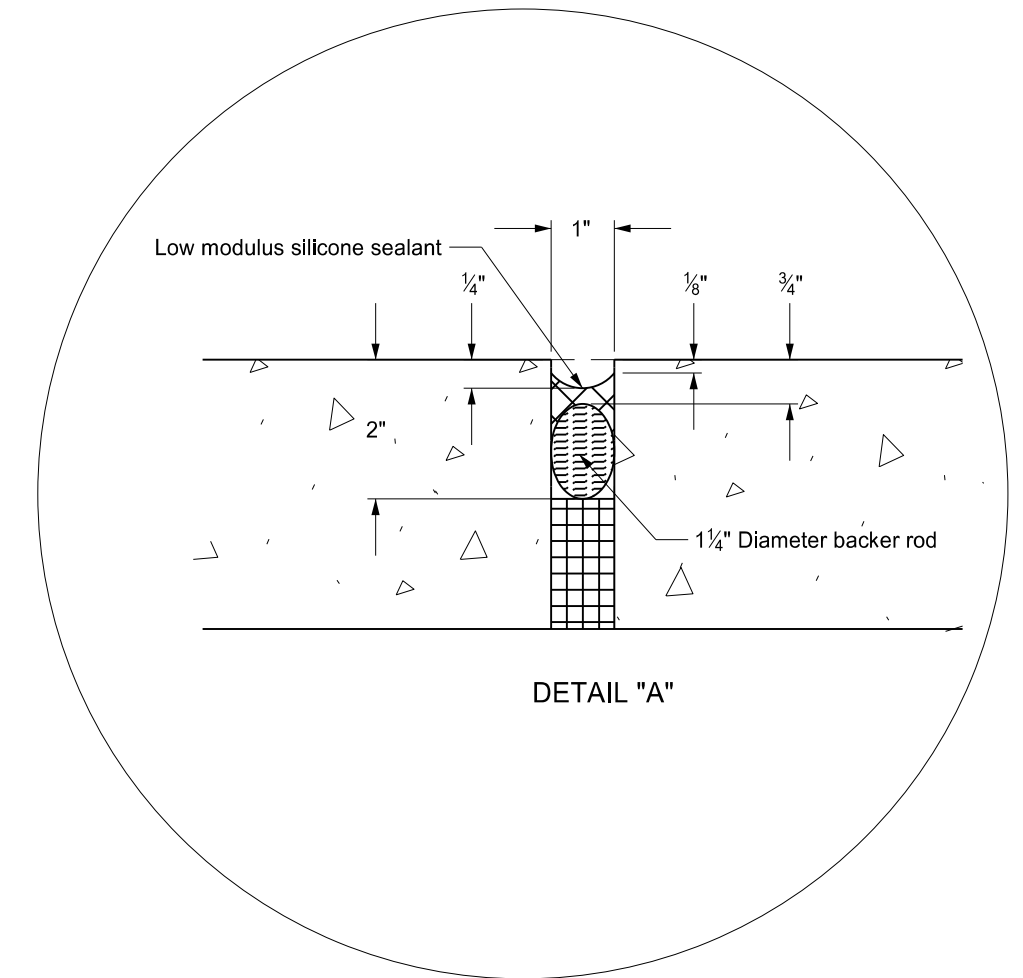
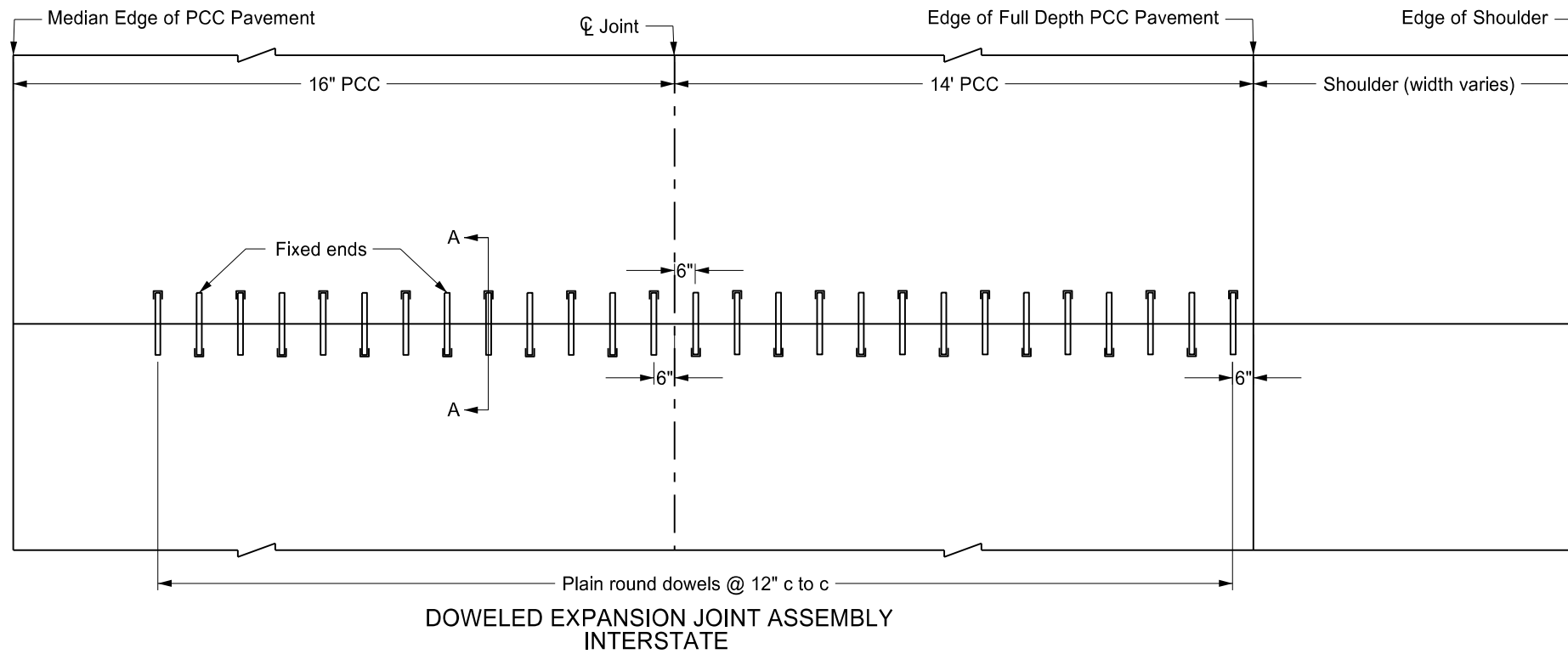

NORTH DAKOTA DEPARTMENT OF TRANSPORTATION	
9-15-2010	
REVISIONS	
DATE	CHANGE
6/23/2014	Removed dowel bar sizes
10/25/2019	Expanded details for clarity

This document was originally issued and sealed by
 Kirk J Hoff,
 Registration Number
 PE- 4683,
 on 10/25/19 and the original document is stored at the
 North Dakota Department
 of Transportation